

**Description:** Explains how to use the IPS150 drives with RS-485 serial communication, including how to setup the drives for RS-485 communication, recommended connections for an RS-485 network with one or more drives linked to a PC and how to use the **IPM MotionStudio – V2.0.1.1** with an RS-485 network of drives.

**Steps to follow:**

1. Setup the drives for RS-485 communication
2. Mount on your PC an RS-485 interface board or an RS-232/RS-485 converter
3. Install on your PC an RS-485 software driver
4. Build the RS-485 network
5. Setup IPM Motion Studio for communication via RS-485 with the drives
6. Develop and test your motion application
7. Set the drives in standalone operation

**Step 1. Setup the drives for RS-485 communication**

In order to activate the RS-485 communication, you need to program and configure all the IPS150 drives from your network for RS-485 mode. The programming must be done using RS-232 communication and includes the following steps for each drive:

1. Perform the hardware and software settings to setup RS-232 communication between IPM Motion Studio and your drive (see Appendices A, B and C for details)
2. Create a new project for an IPS150 drive or if you have a project already defined, open it. If your project has more applications make sure that you select an application for an IPS150 drive
3. Select command "Project | Settings" and click the tab "General". Check "Update firmware" box. If it is checked, go to next step, else use the "Browse" button to select the firmware update file "S007A"

**Remarks:**

- a) *The firmware update file for these drives is a program, to be downloaded into the drive's EEPROM. It works together with the drive's main firmware to add new features or improve the existent ones.*
  - b) *Make sure that you have selected the right firmware update file as indicated above. The version, which is indicated by the last letter, may be equal or higher (e.g. B, C instead of A)*
4. Select command "Application | Firmware Update". On the bottom line of the IPM Motion Studio you'll see the progress of drive programming. Wait until the message: "Entry Point: 0xC000" occurs
  5. Select command "Application | Setup RS485". Choose an axis ID (address) for the drive. The axis ID value must be different for each drive of the network and also different from the PC host address (which is set by default at 255).
  6. Perform the hardware settings to setup the IPS150 drive for RS485 communication (see Appendix D for details).

**Step 2. Mount on your PC an RS-485 interface board or an RS-232 / RS-485 converter**

Usually, the standard PCs do not provide an RS-485 interface. In order to use the IPM Motion Studio to communicate with your drives via RS-485, you need to mount on your PC an RS-485 interface. This interface can be an add-in board or an RS-232 to RS485/RS-422 converter connectable to the standard serial ports of the PC.

Technosoft provides, if needed, RS-232 to RS-485 converters as well as other accessories for RS-485 networking. If you intend to use your own RS-232 to RS-485/RS-422 converter, please note that this should use the RTS line for transmission control, with the RTS signal active high (+5 to +12V) to enable the PC transmission and disable reception. These conditions are usually met by most of the RS-232 to RS-485/RS-422 converters. A typical example is the model IC-485SI from ATEN ([www.aten-usa.com](http://www.aten-usa.com)) that can be used either as RS-232 to RS-485 converter or as RS-232 to RS-422 converter. To use this model as an RS-232 to RS-485 converter, you need to:

- set the switch DCE/DTE on position DCE
- set the switch T-ON R-ON / T-RTS R-/RTS / T-RTS R-ON on position T-RTS R-/RTS
- connect the RS-485 signal +A to converter inputs T+ and R+, the RS-485 signal -B to converter inputs T- and R- and the RS-485 ground to the converter shield<sup>1</sup>

**Remark:** the converter should free the RS-485 line immediately after the last stop bit is transmitted, without other delays.

**Step 3. Install on your PC an RS-485 software driver**

In order to use an RS-232 to RS-485 converter with RTS control of the PC transmissions, you need to install on your PC an RS-485 serial driver. This driver should automatically activate the RTS line during the PC transmissions.

If you don't have an RS-485 driver, we recommend the following drivers:

- for Windows 95 and Windows 98 - Integrity Instruments driver from:  
<http://www.integrityusa.com/download.htm>
- for Windows NT and Windows 2000 – Sealevel driver from:  
<http://www.sealevel.com/catalog/asynsw.htm>.

For the Integrity Instruments driver, the installation instructions are presented in the readme.txt file included in the zip file to be downloaded. For the SeaCOM driver, the installation instructions are presented in Appendices G and H.

---

<sup>1</sup> If you use a non-isolated converter like model IC-485S from ATEN, connect the RS-485 ground to the PC serial connector ground

**Step 4. Build the RS-485 network**

Figures 1 and 2 show how to do the network connections when working with one IPS150 drive linked via RS-485 with a PC equipped with an RS-232 to RS-485/RS-422 converter. Use schematics from Figure 1 if your IPS150 drive is equipped with a standard 9-pin DB9 serial connector (J4), for both RS-232 and RS-485 communication. Use schematics from Figure 2 if your IPS150 is equipped with 2 separate, 3-pin screw terminal connectors, one for RS-232 (J2) and the other for RS-485 (J5).

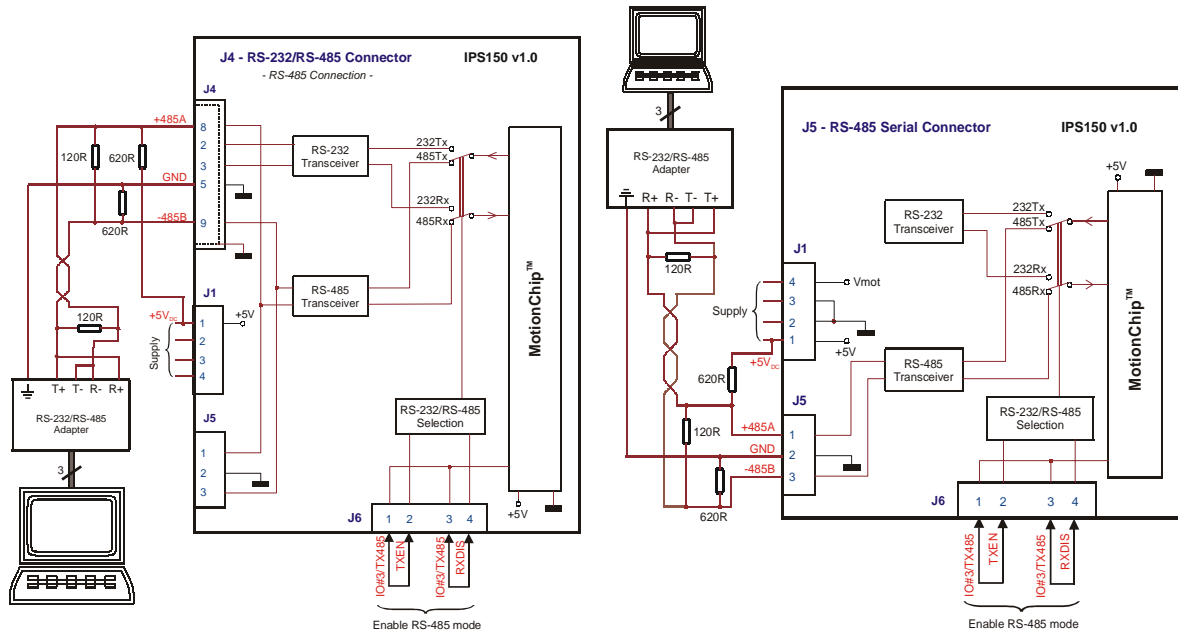
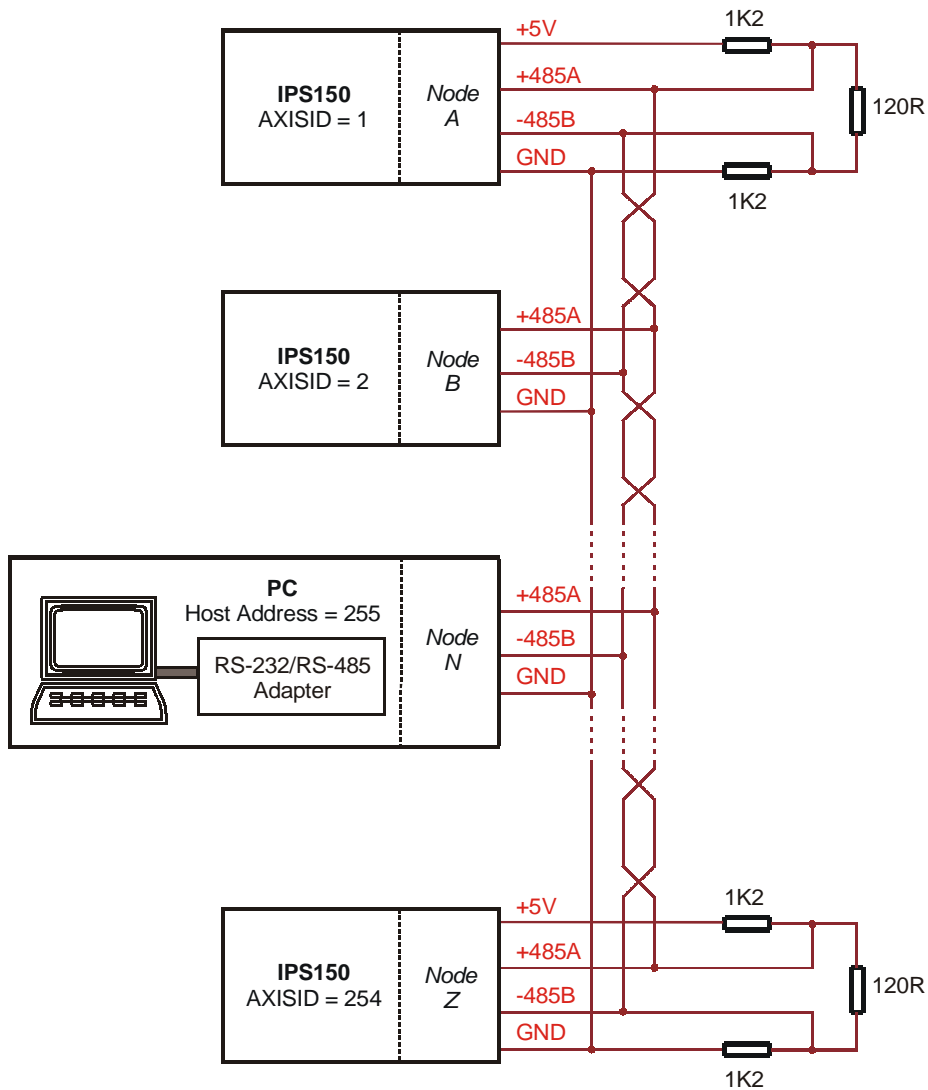

**Figure 1.** RS-485 connections: PC to J4 connector of IPS150. Polarity bias, applied at one network end

**Figure 2.** RS-485 connections: PC to J5 connector of IPS150. Polarity bias, applied at one network end

Figure 3 presents how to do the network connections when working with more drives and a PC equipped with an RS-232 to RS-485/RS-422 converter.

Multiple-Axis RS-485 Network connection



**Figure 3.** RS-485 connections: PC and multiple drives. If cable length is over 150 m, apply polarity bias circuits at both network ends as shown in this figure. If cable length is under 150m, you may apply a polarity bias circuit only at one network end, as shown in Figures 1 and 2

**Step 5. Setup IPM Motion Studio for communication via RS-485 with the drives**

1. Create in your IPM Motion Studio project an application for each drive. It is not necessary to perform also the setup and tuning for each drive. This operation may be done later using RS-485 communication
2. Select command "Projects | Settings" and click the tab "General". Set for each application an "Axis Number" equal with the drive address value (axis ID) set in the corresponding drive at Step 1, point 5. For example if you use 3 drives and you have set their axis ID as 1, 2 and 3, you should also have 3 applications in your IPM Motion Studio project with the "Axis Number" values: 1, 2 and 3. Close dialogue with OK
3. Power-on the drives
4. Perform the software settings to setup RS-485 communication between IPM Motion Studio and yours drives (see Appendix E for details)

If the communication works properly, you'll see displayed on the bottom line of the IPM Motion Studio the product ID of the drive (for example: "P073.001.C0x.S00A"), which is read from the EEPROM memory of the drive. Select one by one all the applications to check that the communication works properly with all the drives.

**Step 6. Develop and test your motion application**

Once you have setup the RS-485 communication, you can choose one by one the drives to work with by selecting the application which has the "Axis Number" identical with the axis ID of the drive. Thus for each drive, you can perform the same operations you usually do with one drive connected via RS-232: setup and tune the drive for the motor and load used, develop and test the motion to be executed.

**Step 7. Set the drives in standalone operation**

By default, when you create a new application (either by adding one to an existent IPM Motion Studio project, or by starting a new project which automatically creates a first application), the IPM Motion Studio supposes that you first intend to test the application. Therefore, the TML (Technosoft Motion Language) program of this application, which includes all the drive settings and the motion to be performed, is compiled for and downloaded into the volatile SRAM memory of the drive. The advantage of using for tests the SRAM memory of the drive, instead of the non-volatile E2ROM memory, is the faster access resulting in a shorter download time. The SRAM speed advantage is especially evident with TML programs of large dimensions. However, once the testing phase is passed, in most of the cases, the TML program should finally be saved in the non-volatile memory of the drive. In plus after power on, the drive should start executing automatically the TML program e.g. should operate in standalone mode, also called AUTORUN mode.

In order to set all the drives for standalone operation, you need to perform the following steps:

1. Select command "Projects | Settings" and click the tab "Linker". Select one by one the applications associated with your drives and at "Memory Type" select E2ROM. Close the dialogue with OK.
2. In project window, select one by one the applications. For each application, you need to recompile the TML program for E2ROM memory and then to download it. This operation is done as follows:
  - Select command "Build | Generate Code"
  - Select command "Build | Rebuild All"
  - Select command "View". If on the menu items "Command Interpreter" is not checked, select it, else go to command "Windows" and select the "Command Interpreter" window to bring it in front.
  - Type on the command interpreter prompter, the following commands  
TML>**axisoff**<Enter>  
TML>**end**<Enter>
3. Select command "Application | Download Program". On the bottom line of the IPM Motion Studio you'll see the progress of drive programming. Wait until the message: "Entry Point: 0x4000" occurs

After all the drives have been reprogrammed, power them off and on to activate the stand-alone operation.

**Remark:** After power on, the default baud rate of the Technosoft drives is 9600. If you have set a different baud rate for in IPM Motion Studio, each time you open IPM Motion Studio, it will try to detect the drives baud rate, then change them to the value you have chosen. The process is transparent for you as long as IPM Motion Studio is able to perform these operations successfully for all the drives. However if, with IPM Motion Studio open, you set the drives for standalone operation, you may temporary loose the communication if the IPM Motion Studio is set for a baud rate different from 9600 which is the drives value after reset. In order to restore it, you need to press the "Refresh Serial Settings" button or select the command "Tools | Refresh Serial Settings". This command will start the automatic baud rate detection, followed by the baud rate change to the value you have chosen for IPM Motion Studio.

## Tips regarding standalone operation of the drives

### 1. How to change the baud rate of the drives set in standalone operation

By default, the drives set in standalone operation start after power on with a baud rate of 9600. In the absence of the IPM Motion Studio this value remains unchanged. If your host uses a different baud rate, it is possible to program the drives to automatically change, after power on, their baud rate to match that of the host. You can do this by adding the instruction for baud rate change, at the beginning of your motion program, in the following way:

1. In Project window, click Motion, then select the first line
2. Click "MISC" (Miscellaneous) button from group "Assignment & data transfer". At Serial Communication, select "Set SCI Baudrate to" and select the desired baud rate
3. Close dialogue with OK. Click button "Move Up" to set first this instruction, in order to execute as soon as possible after power-on. Close Motion dialogue with OK
4. You need to recompile and download the program as presented in steps 2 and 3 from the paragraph "Step 7. Set the drives in standalone operation"
5. Power off then power on the drive to activate the new program

### 2. How to reprogram the drives set in standalone operation

In a more general way, you can change the TML motion program of the drives that are set in standalone operation without removing the drives from this mode. The procedure is:

1. Modify the motion program
2. Select commands "Build | Generate Code", then "Build | Rebuild All" to recompile and link the program
3. Stop execution of the program running on the drive ( started when the drive was powered on). For this operation you need to open the command interpreter and type on the prompter, the following commands

```
TML>axisoff<Enter> // disable motor control
TML>end<Enter> // stop program execution
```
4. Select command "Application | Download Program" to download the new program into the drive
5. Power off, then power on the drive to activate the new program

### 3. How to get out the drives from standalone operation

If you want to stop the drive executing automatically after reset the program downloaded into the E2ROM memory, you need to get out the drive from standalone operation. The procedure depends on the type of serial communication, RS-232 or RS-485, for which the drive was setup.

If the drive is set for RS-485 communication, do the following steps:

1. Stop execution of the program running on the drive (started when the drive was powered on). For this operation you need to open the command interpreter and type on the prompter, the following commands

```
TML>axisoff<Enter> // disable motor control
TML>end<Enter> // stop program execution
```

2. Select command "Projects | Settings" and click the tab "Linker". At "Memory Type" select "External parallel" (SRAM). Close with OK.
3. Select command "Application | Setup RS485". Use the same value programmed before in the drive to keep unchanged the axis ID (address) for the drive. The axis ID value must be different for each drive of the network and also different from the PC host address (which is set by default at 255).
4. Modify (if needed) the motion program. To execute it, just press the "Run" button from the IPM Motion Studio<sup>2</sup>.

If the IPS150 drive is set for RS-232 communication, remove the AUTORUN jumper placed between pins 7&8 of the J9 connector.

**Warning:** When the drives are set in standalone operation, do not use the IPM Motion Studio button "Run" to compile, download and test a new motion program. *Use only the procedure presented in the above paragraph "How to reprogram the drives set in standalone operation".* If the "Run" button is used, you download the new application on the same memory locations from where a program is executing. This operation may lead to a corrupted program with unpredictable results. Failing to respect this rule, may lead on the IPS150 drive set for RS-485 communication, to the lost of the communication and the need to redo the drive reprogramming for RS-485. This situation occurs if the program downloaded into the E2ROM memory, which is responsible with the RS-485 communication setup, becomes corrupted

### **Appendix A. IPS150 hardware settings for RS-232 communication**

1. Power-Off the IPS150 drive
2. Connect an RS232 serial cable between your PC and J4 (or J2) connector of the IPS150. If IPS150 is equipped with J4 connector (9-pin serial DB9), use a 9-wire standard serial cable non-inverting (one-to-one) or do connections as in Figure A.1. If IPS150 is equipped with J2 connector (3-pin screw terminal), do connections as in Figure A.2
3. Remove all jumpers from J6 and J9 connectors of IPS150
4. Power-On the IPS150 drive

### **Appendix B. IPM Motion Studio software settings for RS-232 communication**

1. Select command Tools | Options and click the tab "Serial port"
2. Select from "Serial type" RS-232 (default)
3. Select the desired baud rate from "Baud Rate". Default value is 9600
4. Set the "Axis ID of the drive connected to PC" as 255 (default)
5. Select from "COM Port Number" the serial port of your PC, where you have connected the serial cable. By default COM2 is selected
6. Leave the other parameters on their default settings: Open COM Port Exclusive – not checked, Read interval timeout – 1000 ms, Timeout multiplier – 700 ms, Timeout constant – 400 ms, Wait after RUN – 2000 ms, Enable Idle Board Checking – not checked, Show

---

<sup>2</sup> When the Run button from IPM Motion Studio is pressed, the following commands are executed: Build | Generate Code, Build | Rebuild All, Reset Drive, Resynchronize serial communication, Application | Download & Execute. The commands refer to the active (selected) application

- firmware in status bar instead of product ID – not checked, Enable serial communication logging to the output window – not checked
- 7. Press the OK button

If the communication works properly, you'll see displayed on the bottom line of the IPM Motion Studio the product ID of the drive (for example: "P073.001.C0x.S00A"), which is read from the EEPROM memory of the drive.

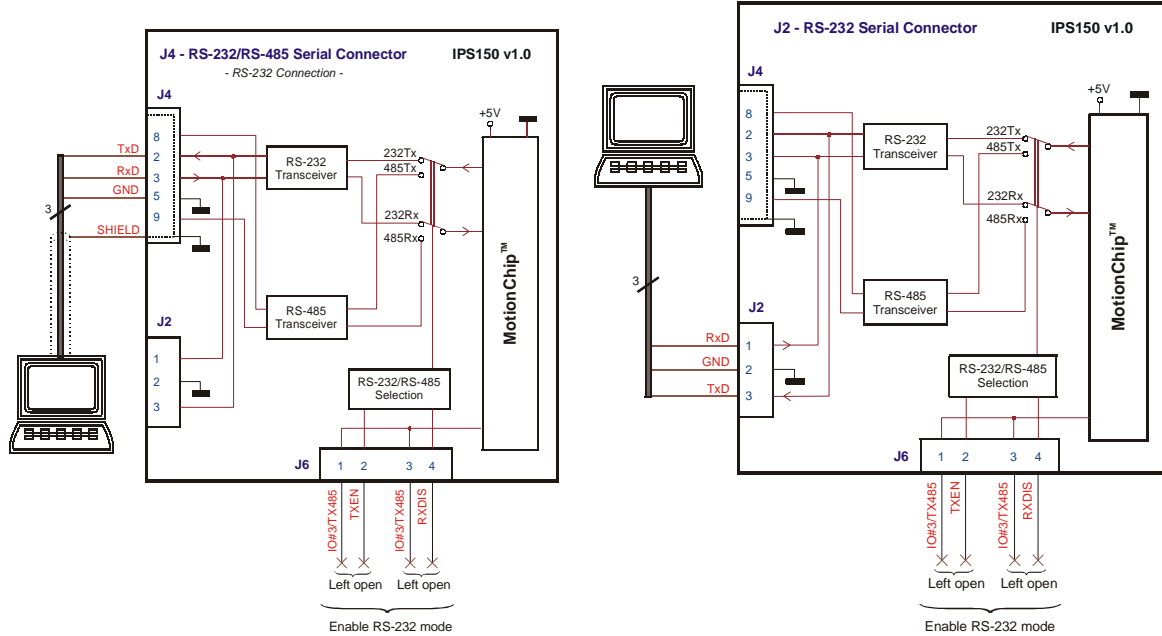

Figure A.1. RS-232 serial connections for IPS150 with J4

Figure A.2. RS-232 serial connections for IPS150 with J2

**Appendix C. RS-232 communication troubleshoots**

If the RS-232 communication does not operate properly, you'll get an error message.

1. If the error message is "Cannot open the serial port", the serial port selected from "COM Port Number" is used by another device of your PC (mouse, modem, etc.). Click "Cancel", select another serial port and try again
2. If the error message is "Cannot synchronize computer and drive baud rates", click "Work Offline", then check:
  - Serial cable connections;
  - Serial cable type. If your PC serial port is DB9 you need a standard male-female 9-wire non-inverting (one-to-one) cable. If your PC serial port is DB25, use also a standard 25-to-9 pin serial adapter;

- Select command “Project | Settings” and press “General” tab. Check if “Axis Number” of your active application is 255 (When RS-232 is used, “Axis Number” must have the same value as “Axis ID of the drive connected to PC”)
- In case your drive is set for RS-485 mode (see RS-485 Setup), remove the AUTORUN jumper from the drive’s I/O connector J9 pins 7&8 and also the jumpers from the drive’s RS-485 address connector J6 pins 1&2 and 3&4. Power off, then power on the drive to restore RS-232 mode

After you fix the problem, press “Refresh Serial Settings” button to restore communication.

3. If the communication operates usually but gives communication errors from time to time, check the following:
  - If your PC has an earth connection
  - If your drive is linked to earth (for IPS150 drives connect the earth to the supply GND)
  - Try to increase the “Read interval timeout”, “Timeout multiplier” and “Timeout constant” parameters. Note that these parameters are related to PC serial operation and usually the default values for these parameters do not need to be modified

#### **Appendix D. IPS150 hardware settings for RS-485 communication**

1. Power-Off the IPS150 drive
2. Disconnect the PC serial cable from J4 (or J2) connector of IPS150
3. Put a jumper to J9 connector, between pins 7&8, to set the drive in AUTORUN mode
4. Put a jumper to J6 connector, between pins 1&2 and 3&4 to enable the RS485 transceiver on the IPS150 drive

#### **Appendix E. IPM Motion Studio software settings for RS-485 communication**

1. Select command Tools | Options and click the tab “Serial port”
2. Select from “Serial type” RS-485
3. Select the desired baud rate from “Baud Rate”
4. Set the “Axis ID of the PC” different from any drive address. The easiest way is to leave it as 255 (default) and make sure that all the drives have a different address.
5. Select from “COM Port Number” the serial port of your PC, where you have connected the serial cable. By default COM2 is selected
6. Leave the other parameters on their default settings: Open COM Port Exclusive – not checked, Read interval timeout – 1000 ms, Timeout multiplier – 700 ms, Timeout constant – 400 ms, Wait after RUN – 2000 ms, Enable Idle Board Checking – not checked, Show firmware in status bar instead of product ID – not checked, Enable serial communication logging to the output window – not checked
7. Press the OK button

If the communication works properly, you’ll see displayed on the bottom line of the IPM Motion Studio the product ID of the drive (for example: “P073.001.C0x.S00A”), which is read from the EEPROM memory of the drive. Select one by one all the applications to check that the communication works properly with all the drives.

**Remark:** Instead of the product ID you may also see the messages “RS-485 Mode” or “Board Present”. First message is displayed after you have opened IPM Motion Studio, but before opening a project. In this stage, the software doesn’t know with which drive (axis ID) it should try to communicate. The message “Board Present” occurs when the product ID is not recognized or is missing, being by mistake erased from the drive EEPROM memory. For this situation, Technosoft provides a specific tool, called **IPMSN.exe** (IPM Serial Number Editor), which allows you to restore the product ID. This tool is installed in the main folder of the IPM Motion Studio.

**WARNING**

**On some PC configurations and operating systems, you may encounter communication problems in RS-485 mode when running your application. In such cases try to reduce the communication speed progressively, starting with 115200 (use the ‘Tools | Options’ menu).**

**Appendix F. RS-485 communication troubleshoots**

If the communication does not operate properly, you’ll get an error message.

1. If the error message is “Cannot open the serial port”, the serial port selected from “COM Port Number” is used by another device of your PC. Click “Cancel”, select the PC serial port used for RS-485 operation and try again
2. If the error message is “Cannot synchronize computer and drive baud rates” click “Work Offline”, then check:
  - RS-485 cable connections, presence of the 120 ohm terminal resistors at the two ends of the network and the presence of the bias circuit(s) to keep the line level in idle mode.
  - If you use an RS-232/RS-485 converter with automatic control of transmission, check the specifications. Usually these devices free the RS-485 lines when a transmission ends, only after a time equivalent with transmission of another byte. You can’t use these devices, as the Technosoft drives respond to a data request faster. For correct operation you should use a device that frees the RS-485 lines immediately after the last stop bit transmitted.
  - Select command “Project | Settings” and press “General” tab. Check if the “Axis Number” for all the applications associated with the drives from the network is correctly set. The “Axis Number” values should be the same as those programmed in the drives. Each drive must have a different axis number e.g. address. No drive can have the same address value as that set for the “Axis ID of the PC” e.g. the PC address.
  - Check if your drive is set for RS-485 operation e.g. if the AUTORUN jumper is connected on J9 connector between pins 7&8 and on J6 connector you have jumpers between pins 1&2 and 3&4. If some of these jumpers are missing, connect them, then power off and power on the drive to set it for the RS-485 operation
3. If the communication operates usually but gives communication errors from time to time, check the following:
  - Check the network ground connection. This link is mandatory if the drives don’t have the same ground
  - Try to increase the “Read interval timeout”, “Timeout multiplier” and “Timeout constant” parameters. Note that these parameters are related to PC serial operation and usually the default values for these parameters do not need to be modified

**Appendix G. RS-485 driver installation on Windows 2000**

1. Download from <http://www.sealevel.com/catalog/asyncsw.htm> the *SeaCOM Windows* driver package and install it
2. On your Windows 2000 system, click on the "Start" button from the task bar and choose "Setting | Control Panel"
3. Double-click on the "System" icon and select the tab "Hardware"
4. Press the "Device Manager" button
5. At "Ports", select Communication Port (COM1) if you want to communicate on COM1 or select Communication Port (COM2) if you want to communicate on COM2, then select "Action | Properties" command
6. Select the tab "Driver", press the "Update Driver" button and then the "Next" button
7. Select "Display a list of the known drivers for this device so than I can choose a specific driver" radio button and press "Next" button
8. Select "Show all hardware of this device class" radio button
9. In the "Manufacturers" list, select the "Sealevel System, Inc.", and in the "Models" list select "COMM+2/EX: 2 Port RS-232/422/485 (Port1)". Press the "Next" button
10. Respond "Yes" to the question "Do you want to continue installing this driver"?
11. Press Next button, and then the Finish button
12. In the Control Panel double-click on the "System" icon, select the tab "Hardware" and press the "Device Manager" button
13. At "Ports", select as Communication Port (COMx) the same as that selected at step 5., then select the command "Action | Properties". Select the tab "Advanced" and at "RS-422/485 Control Options", check "Auto RTS RS-485"

**Appendix H. RS-485 driver installation on Windows NT**

1. Download from <http://www.sealevel.com/catalog/asyncsw.htm> the *SeaCOM Windows* driver package and install it
2. On your Windows NT system, click on the "Start" button from the task bar and choose "Setting | Control Panel"
3. Double-click on the "Advanced Ports" icon and select the tab "Advanced"
4. Select the COM port and at "RS-485 Options" check "Auto RTS-485"