

Problem: For new users of an intelligent drive, starting to implement a motion control application can be a quite complex task. You need to know how to hook-up the components of the motion system, to configure them (motor, sensors and drive), test their functionality, identify parameters and tune controllers. Finally, execute a simple movement to validate the basic system functionality and focus on your real motion application.

Solution:

- ◆ **Drive** : Technosoft Intelligent Servo Drive **IPS150**
- ◆ **S/W environment** : Technosoft **IPM MotionStudio – V2.0.1.1** or above

Description: This Application Note explains:

- how to perform the basic hardware connections for IPS150 and step motor with or without encoder sensor;
- how to create under the 'IPM Motion Studio' a new project/application for motion control with a step motor;
- how to configure the components of the motion system: motor, sensors, drive;
- how to test the functionality of the system components;
- how to identify the motor parameters and tune the controllers;
- how to run and use data analysis tools;
- how to save your project/application;

Connections:

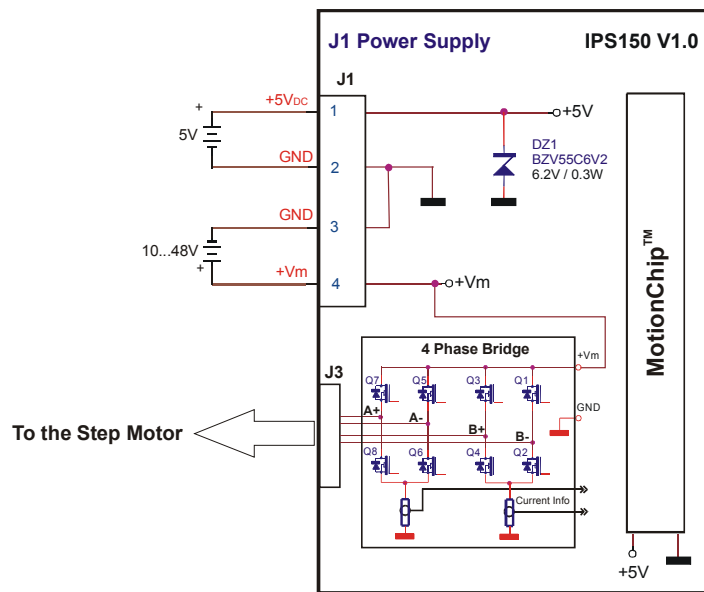

Figure 1. Power Supply – J1 Connector

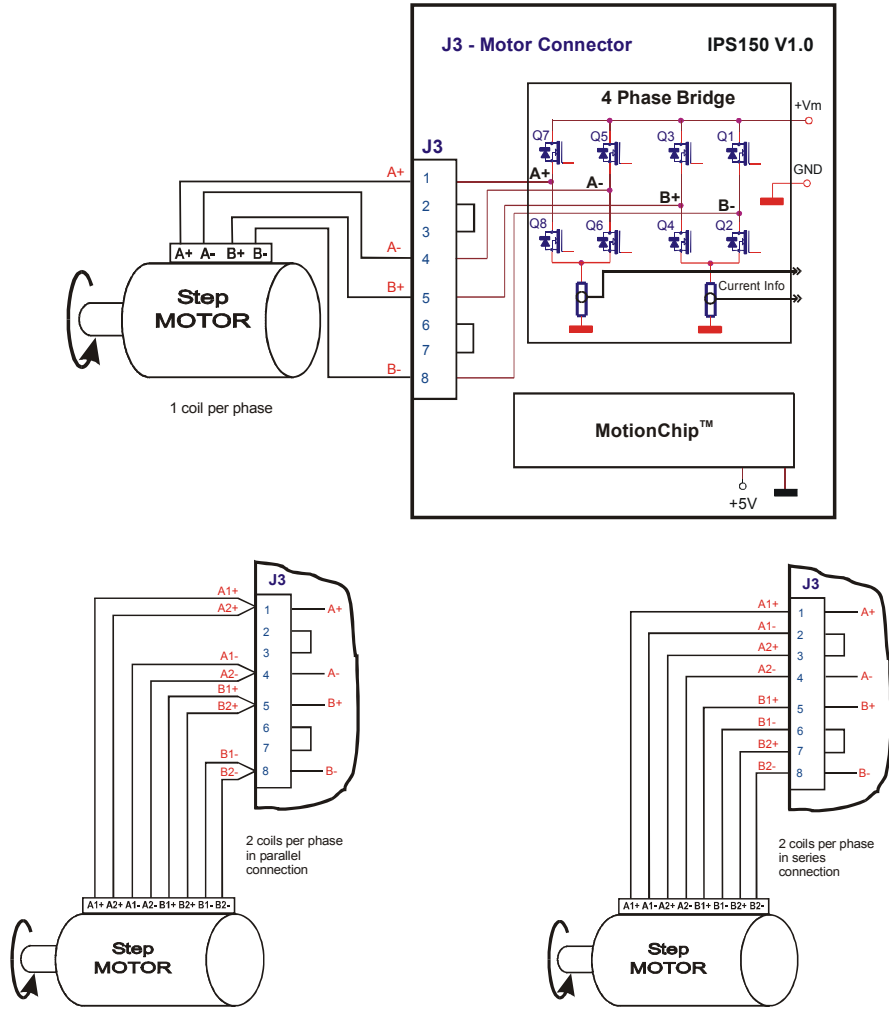

Figure 2. Motor – J3 connector

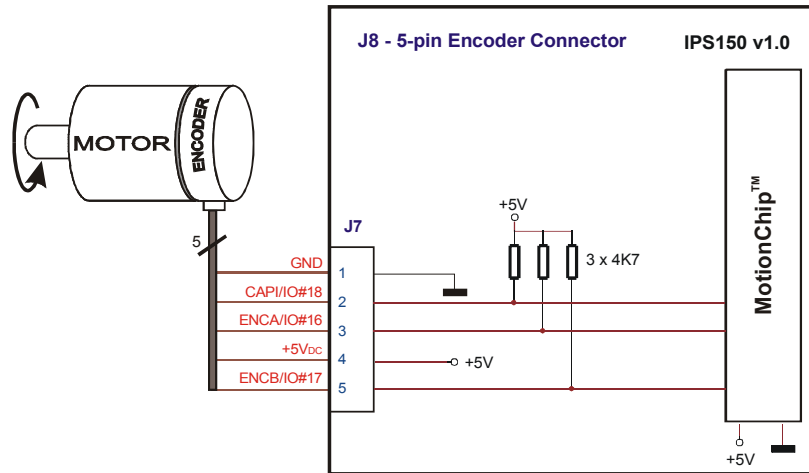

Figure 3. Encoder 5 pins – J8 Connector

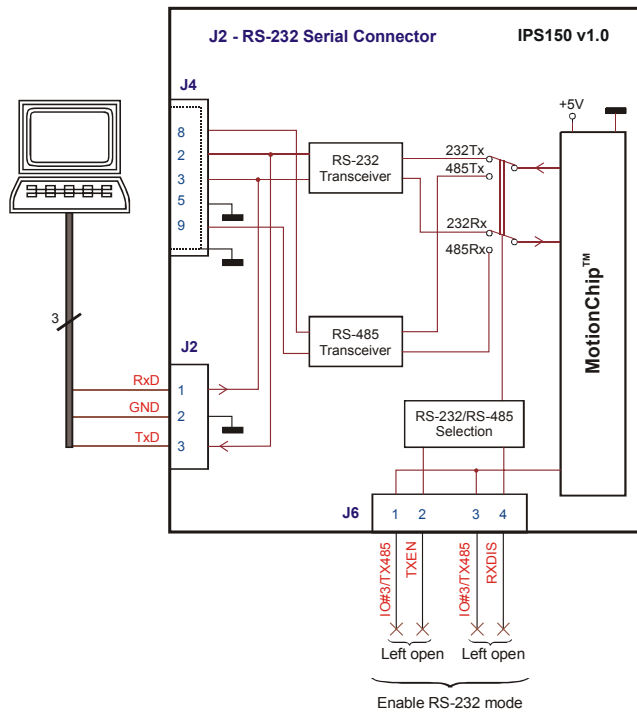

Figure 4. RS-232 connection diagram

Please follow the next steps for a hardware connection of the system components:

1. Connect the power supply, the motor and encoder to the IPS150 drive as you can see in the Figure1, Figure 2 and Figure 3 respectively.
2. Connect the IPS150 drive to the PC computer as you can see in the Figure 4
3. If you have also an IO100S board then please connect it to the IPS150 drive as you can see in the Figure 5
4. First power up the PC
5. Secondly power up the drive

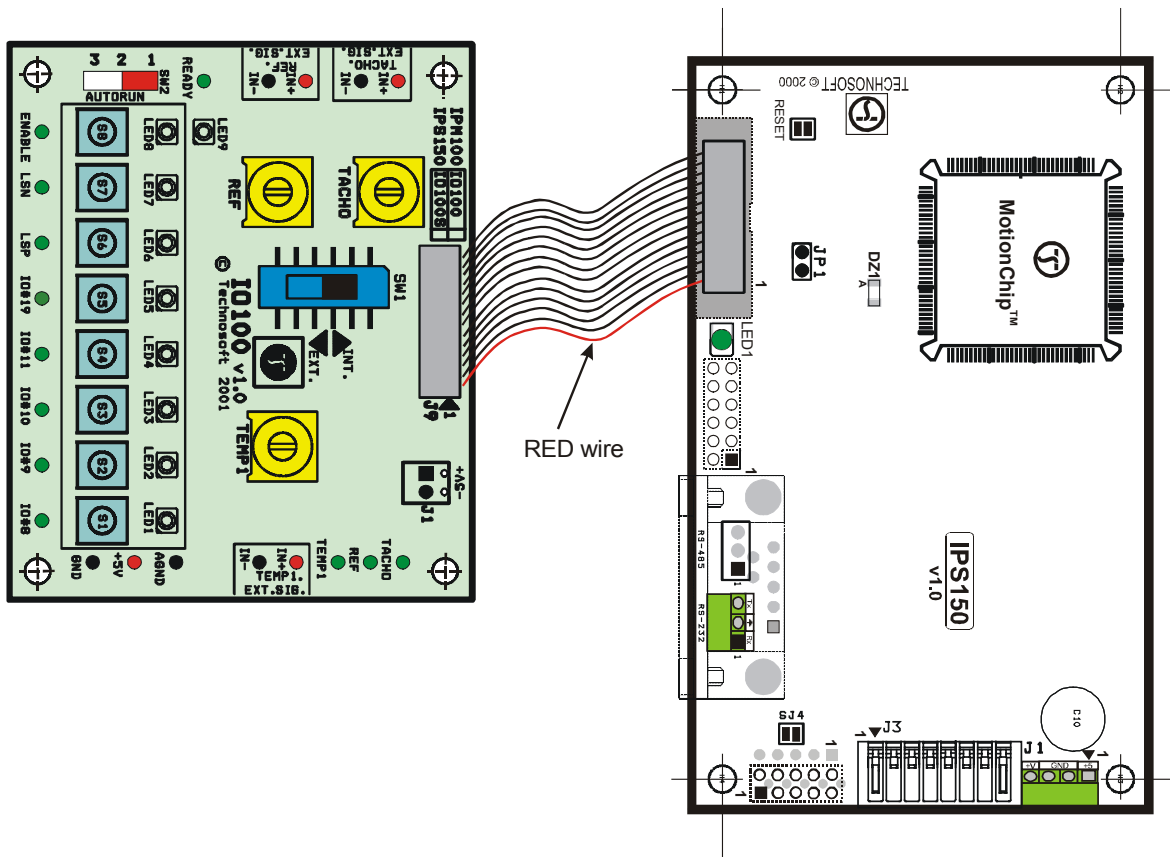

Figure 5. Connecting IO100S with IPS150 board

Project set-up:

1. **Start the execution of IPM Motion Studio;** use the Windows “**Start | Programs | IPM Motion Studio | IPM Motion Studio**” menu command. A dialog as in Figure 6 should be displayed if the communication with the board is established and operates properly.

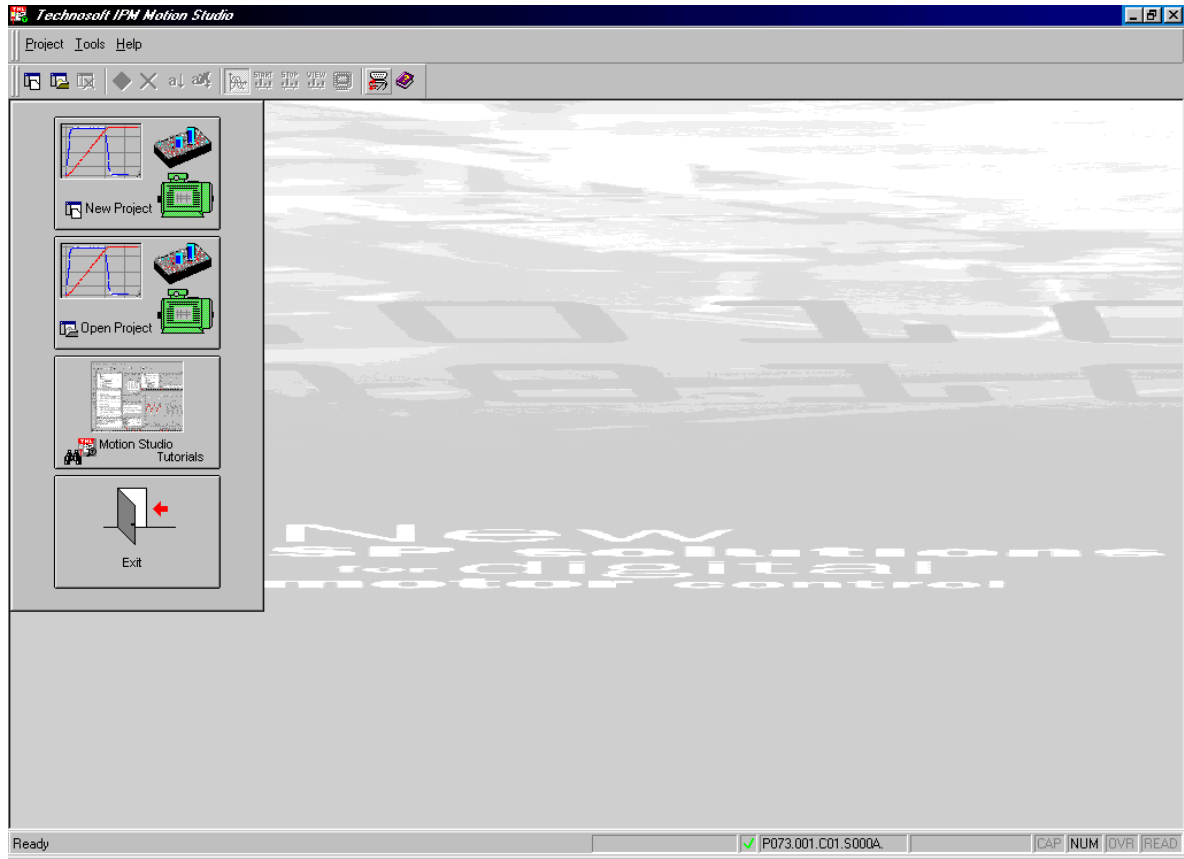

Figure 6. IPM Motion Studio opening screen

Remarks: If the board is not detected, the “**Board NOT found**” message is displayed in the bottom of the program window. In this case check first the serial cable and the power supply connections on the IPS150 and PC, exit the program and launch it again. Alternatively, use the “**Tools | Refresh Serial Settings**” menu command, to retry to communicate with the drive. If the board was detected, the text “**Board present**” or the board type and version (as “**IPS150**”) is displayed in the bottom of program window. In this case, the communication between the IPM drive and the PC works fine, so you can start to use the program.

Otherwise, if the problem persists, follow the next steps:

- a. From the **Tools** menu, choose **Options**. This command opens the **Options** dialog box.
- b. Select the **Serial port** tab from the **Options** dialog box. Select the "**Serial type**" (RS-232 for a single axis structure). Try to start using a smaller **Baud rate** value (as 9600). For single axis structures (only one IPS exists in the system and is connected directly to the PC), set the "**Host Address**" as 255 (default). Select the correct "**COM Port Number**" of the PC, where the serial cable was connected. Press the **OK** button. If the communication with the IPS drive does not operate properly, an error message is displayed "**Cannot open the serial port**". Check if the selected COM port is correct, and not used by another resource of the PC (as mouse, modem, etc). Try again.
- c. If the communication works properly, pressing the **OK** button will exit the **Options | Serial port** dialog, without an error message, and the "**Board present**" or the board type and version (e.g. "**P073.001.C01.S000A**") is displayed in the bottom of program window.
- d. You can in this case try to increase the baud rate, up to the maximal 115 kbaud allowed by the PC.
- e. If the communication operates usually but gives communication errors from time to time, try to increase the "**Read interval timeout**", "**Timeout multiplier**" and "**Timeout constant**" parameters, from the same **Options | Serial port** settings dialog. Note that this is related to some PCs hardware operation, and that usually the default values for these parameters need not to be modified.
- f. Note that the IPM Motion Studio program can be used offline, with no IPS connected to the PC, or powered-up. All the modeling, project and applications definition, and program wizards can be used to configure and parameterize the system and define the motion. Obviously, no IPS information, motion system parameter identification and measurement data can be performed or displayed

2. Start a new project

All the applications in IPM Motion Studio are organized as projects. A project is specific for a selected type of IPM drive (IPM100, IPM240 or IPS150) and a specific motor type (DC brushed, brushless or step motor). Press the "**New Project**" button, and select the type of the drive and motor you installed in your system:

"**IPS150 > Step Motor – Closed Loop**", in order to create such a new project.

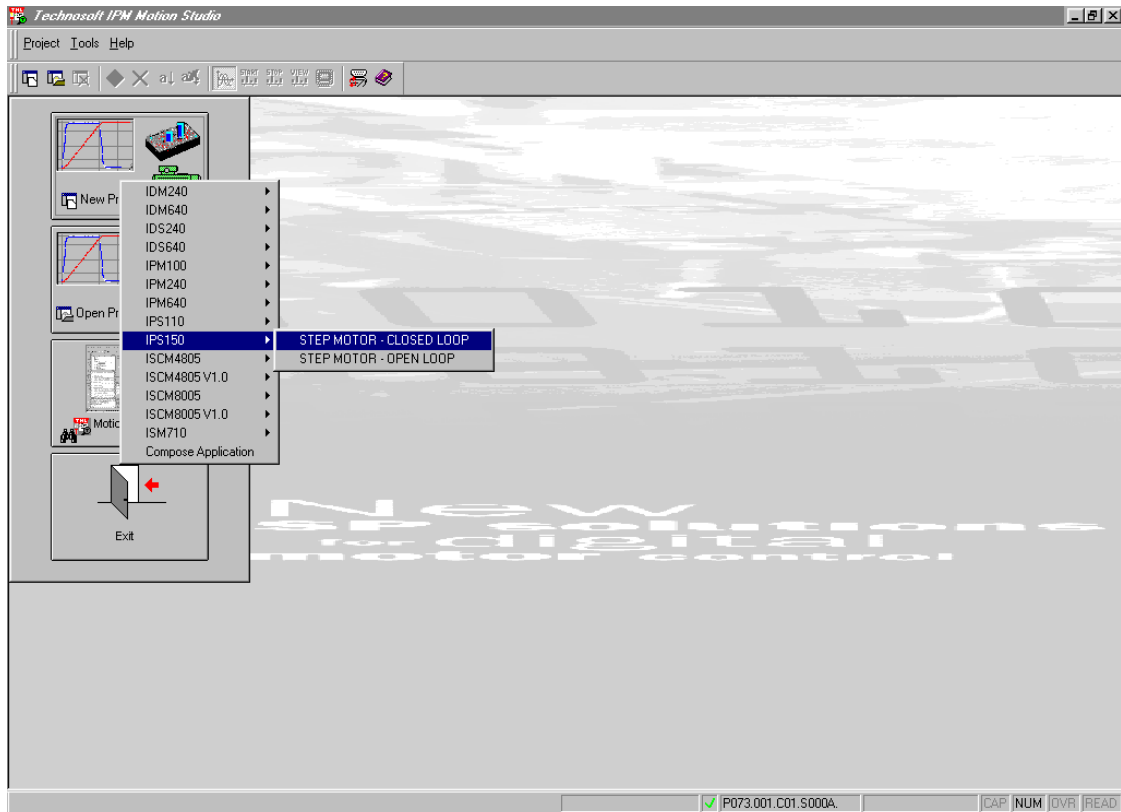

Figure 7. Create a new project in IPM Motion Studio

3. Project diagram structure

A schematic diagram of the motion system will be displayed on the screen. It contains the three basic elements of the system, i.e. the motor and sensors, the drive and, as a separate component, the motion reference generator module. Each of these elements can be selected and will allow you to define the parameters and specific settings associated to that element. Note that the new project is opened with some elements already pre-loaded. You need to change / test / validate these elements, in order to fit to your configuration, as described in the next steps. A small arrow pointing to the left upper corner of the element shows you which element to define/check next.



Figure 8. Motion system diagram in IPM Motion Studio

4. Choose and test the motor and load

Click on the **Motor** icon. The motor and load dialog will be opened, as in Figure 9.

The dialog allows you to choose and / or parameterize your motor and sensors. You can select the motor from a predefined database (“**Default Step motors**” or “**User**”). You can also, starting from a given motor, change its parameters, in order to fit your motor characteristics.

Several specific tests can be performed, allowing you to check the correctness of some motor parameters, the correct operation of existing sensors as encoder and connection of motor to the drive.

WARNING! Note that most of these tests apply power to the motor. Please check carefully the motor parameters, mainly the nominal and maximum current values. Each test applying a voltage to the motor will be performed with a protection limit on the current. If this limit exceeds the motor maximum current, severe damage of the motor can occur!

In order to perform the tests in the proper order, use the “Guideline Assistant” textbox, and follow the steps as described there

Step 1. Select your motor from the corresponding database. If your motor does not exist in the database, proceed through all next steps in order to define your motor and sensors data. In either case, use these steps to verify the new functionality.

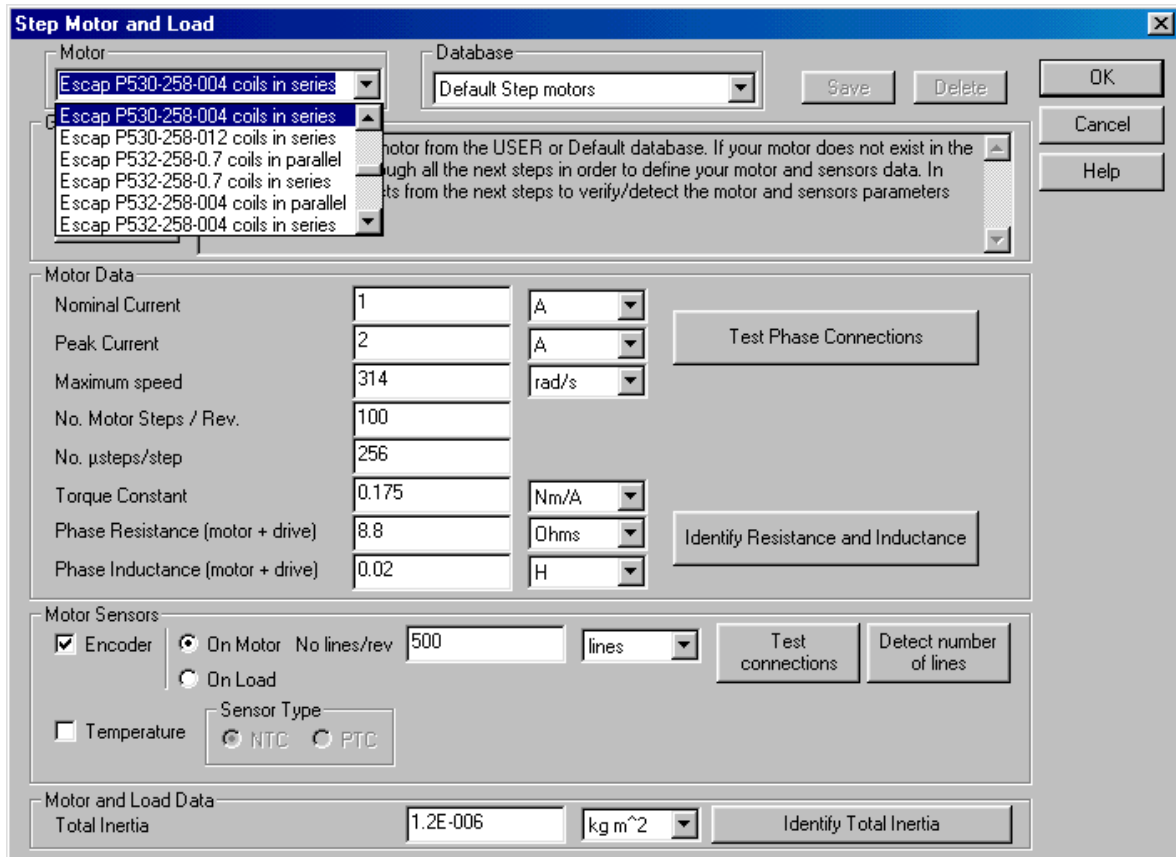

Figure 9. The Motor Dialogue

Step 2. Check the values for *nominal* and *peak currents* (given by the motor catalogue data). Modify these values if needed.

Step 3. Check the *maximum motor speed* value, as a motor catalog data. Modify this value if needed.

Step 4. Check the *number of motor steps*. Modify this value according to motor catalog.

Step 5. Check the **torque constant** value, as a motor catalog data. Modify this value if needed.

Step 6. Check the **phase resistance** and **inductance** values (these are the motor catalogue data). Modify these values if needed.

Step 7. Check-in the “**Encoder**” checkbox if a quadrature incremental encoder is mounted on your motor shaft. Use the “**Test connections**” button in order to verify the operation of A and B encoder signals. The “**Encoder Connection Test**” dialog will open. Follow the “**Test Procedure**” steps. The test will visually show the motor shaft movement, as measured from the encoder signals. You need to manually move the motor shaft. No voltage is applied to the motor for this test. If either A or B signals are defective, the motor position indicator will not move on the dialog while you move the motor shaft.

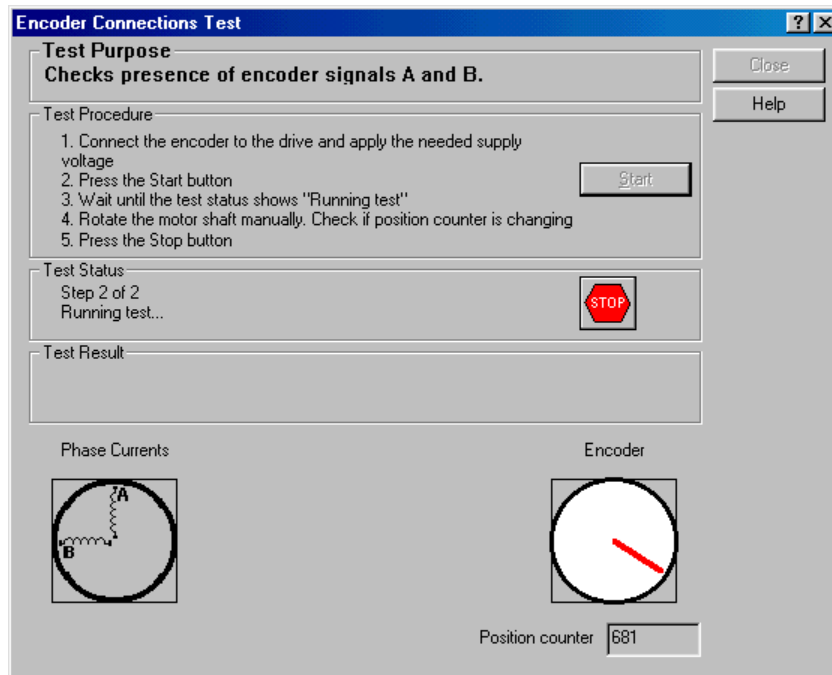

Figure 10. Encoder Connection Test

Step 8. Check in the “**Temperature**” checkbox if you have connected an output of the motor temperature sensor to the corresponding connector pin of the IPS. Check the values of the temperature sensor parameters.

Step 9. Check the value of the **Motor and Load - Total Inertia**. Press the “**Identify Total Inertia**” button to auto-detect this parameter. The “**Total Inertia Identification Test**” dialog will open. Check the value of the test current and that of the current protection to be used during the test and follow the “**Test Procedure**” steps. The test will rotate the motor and estimate the total inertia (motor + load), as reported at motor shaft.

Please note that this test will try to impose a constant torque in the motor. In case that you have a new motor that was not chosen from the motor database, you need to perform the tuning of the current controller before running this test. The current controller tuning can be validated in the Drive dialogue.

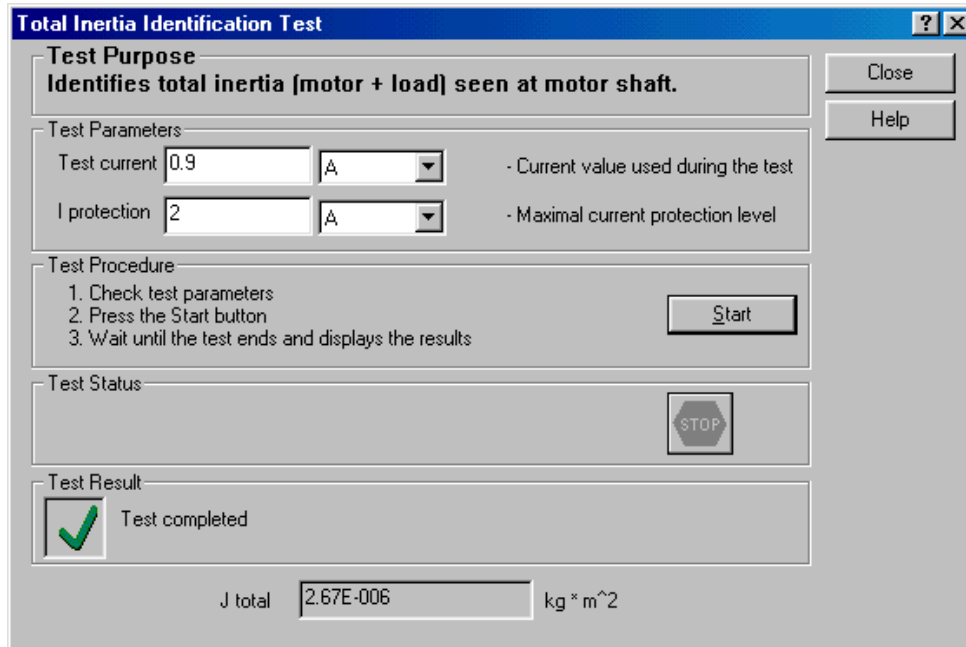

Figure 11. Total Inertia Identification Test

Step 10. Exit the **Motor and Load** dialog, by pressing the **OK** button.

5. Define the control scheme, tune and test controllers

Click on the **Drive** icon. The drive dialog will be opened, as in Figure 12.

The dialog allows you to choose and parameterize the control scheme to be implemented in your application. You can select which control loops to be activated in the scheme, tune and test the activated controllers, and also select and setup the protections of the drive.

Several specific tests can be performed, allowing you to check the behavior of the control loops.

WARNING! Note that most of these tests apply power to the motor. Please check carefully the motor parameters, mainly the nominal and maximum current values. Each test applying a voltage to the motor will be performed with a protection limit on the current. If this limit exceeds the motor maximum current, severe damage of the motor can occur!

In order to perform the tests in the proper order, use the “**Guideline Assistant**” textbox, and follow the steps as described there

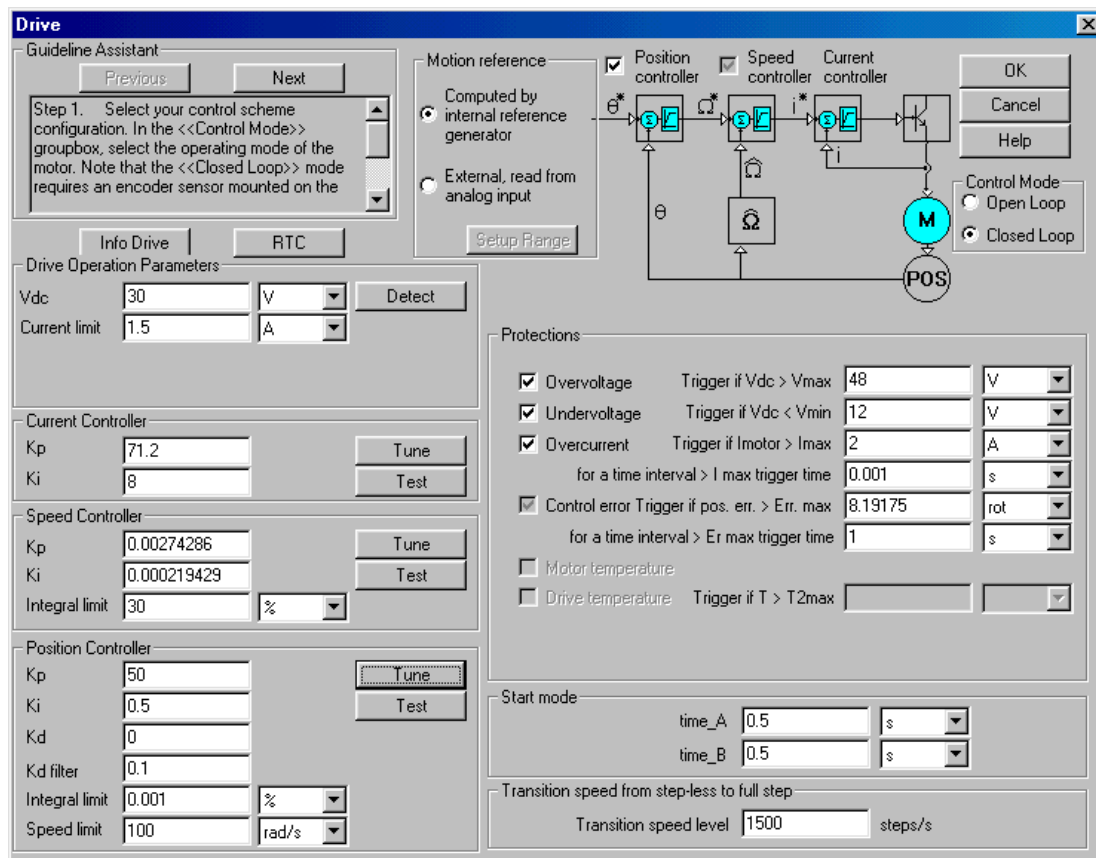

Figure 12. The Drive dialog

Step 1. Select your controller scheme configuration. Check/uncheck the position controller and the Control Mode (**Open Loop** or **Closed Loop**) to be used. Note that the Closed Loop mode requires an encoder. Thus, if encoder sensor was not defined in the motor dialog, the Closed Loop mode is not selectable.

Step 2. In the “**Motion reference**” group-box, select the motion reference type to be used when the motion will be executed. Use the “**Internal Reference Generator**” selection for motions generated through TML motion commands. In this case, the reference will be defined at a latter stage, in the “**Motion**” block of the motion system diagram. If an external analog reference is used during the motion, use the “**Setup Range**” button to set up its parameters.

Step 3. In the “**Drive Operation Parameters**” group-box set the value of the DC voltage power supply (**V_{dc}**). Use the “**Detect**” button to measure its actual value as applied to the drive. The “**V_{dc} Detection Test**” dialog will open. The test will measure the actual value of the power supply voltage applied to the IPS drive.

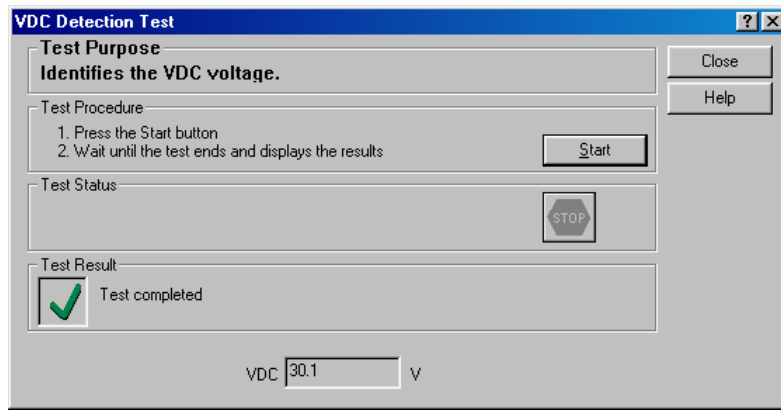

Figure 13. V_{DC} Detection Test

Also set the “**Current Limit**” parameter, e.g. the maximum current value, controlled by the drive during motion.

Step 4. In the “**Current Controller**” group-box you can set the current controller parameters **K_p** (proportional) and **K_i** (integral).

Use the “**Tune**” button to compute these parameters based on the imposed dynamical performances of the closed loop, and on the system parameters. The “**Current Controller - Tuning**” dialog will open in this case. If you set the **damp factor** and the **passband** of the closed control loop, the program will automatically compute the controller coefficients, based also on motion system parameter values. Expected system response to a step reference input in the controller is graphically displayed, as well as the frequency characteristic of the closed loop structure. Once you exit this dialog by pressing the **OK** button, the newly computed controller parameters replace the previous values.

If you are not comfortable with the damp factor and passband parameters, you may cancel the Current Controller – Tuning dialogue and type directly the **K_p**, **K_i** coefficient values in the Current Controller group-box:



Figure 14. Current Controller group-box

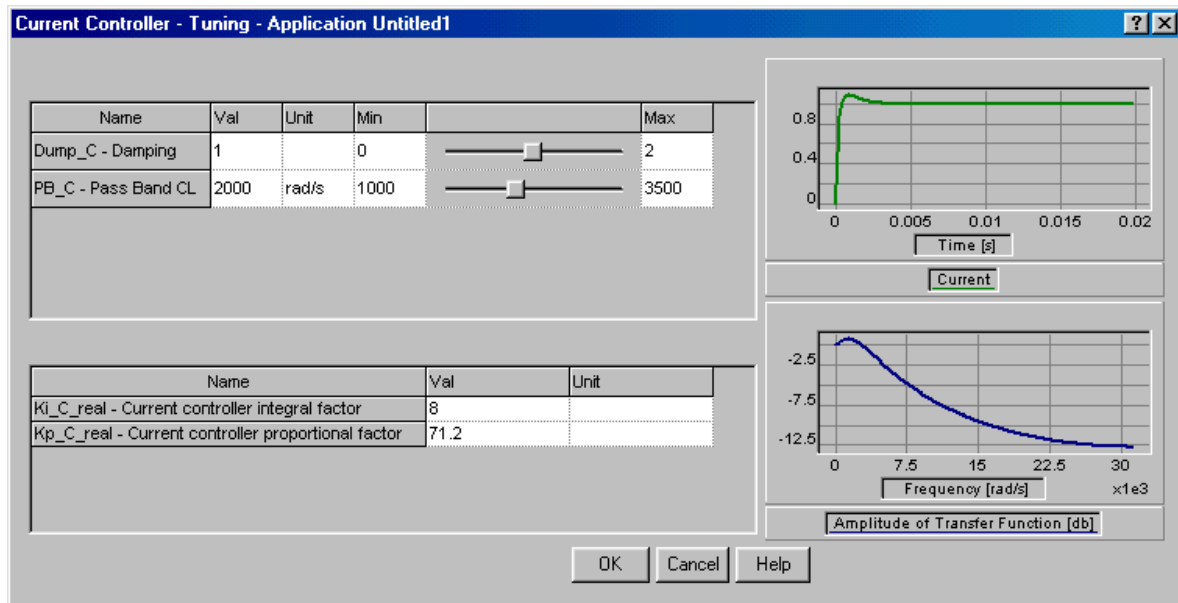

Figure 15. Current Controller Tuning

Use the “**Test**” button in order to test the step response of the closed current loop, for the actual values of the controller parameters. The “**Current Controller Tuning Test**” dialog will open.

The test has two phases:

- Set-up test parameters (‘**Test parameters**’ tab)
- Run the test. (‘**Test**’ tab)

In the ‘**Test Parameters**’ tab you can define the test parameters: check the value of the current reference to be used during the test, as well as the protection current value.

The test applies power to the motor. It applies a step current of “Test current” value, to the motor. The reference (IQREF) and measured (IQ) currents, as well as the reference voltage (UQREF) applied to the motor during the test are then displayed at the end of the test.

The test controls the current applied to the motor as imposed by the user, as the “Test current” parameter from the “Test Parameters” group box. When entering the dialog, the program suggests a value for this current, computed as the half of the nominal motor current. You may change this value, within a specific range, limited by motor and drive maximum accepted currents. The “Iprotection” parameter is used to set the value of the current for which the over current protection will be activated during the test. If this value is reached during the test, then the test execution is stopped. See the time diagram included in the dialog in order to have a better understanding of the meaning of these parameters.

In order to perform the test, follow the “Test Procedure” indications.

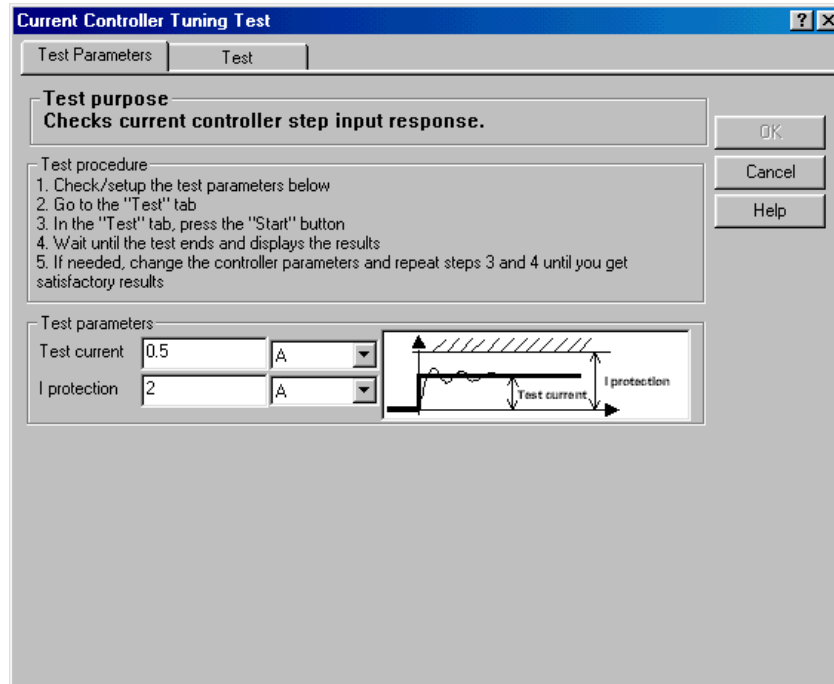

Figure 16.a. Current Controller Tuning Test – 'Test Parameters' settings

The 'Test' tab is used to run the test. In this "Test" tab press the Start button and wait until the test ends and displays the results.

If needed, change controller parameters and repeat the procedure (press the Start button etc.) until you get satisfactory results.

You can change the controller parameters by modifying the value of the parameter in the corresponding edit box or by dragging the associated slider. To modify the range of values for the slider you can use the spin buttons (for minimum and for maximum limit values).

Note that the current min/max range is a sub-range of the absolute range. The absolute limits are computed and depend on specific scaling factors and parameters of the system. Note that a sub-range of the maximum absolute range will allow fine adjustments of the parameters and eventually will reduce the risk of unstable control loop behavior at sudden changes of parameter value.

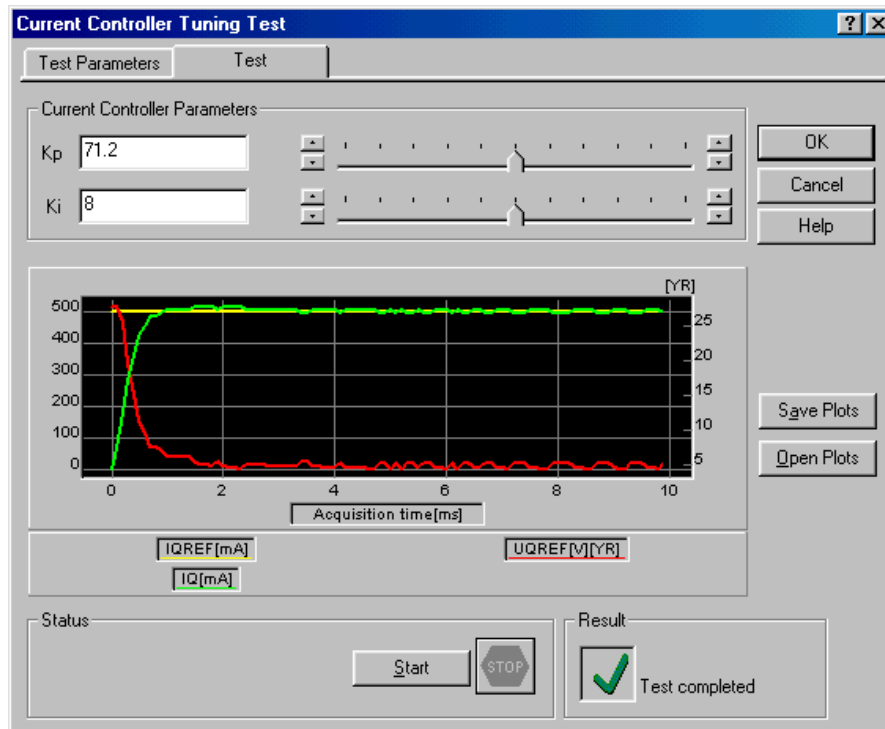

Figure 16.b. Current Controller Tuning Test – ‘Test’ running

If the test fails, check the following:

- Check if the Technosoft drive is powered correctly (use for example, the “VDC Detection Test” from the Drive dialog, to measure the DC-link voltage applied to the power transistors of the Technosoft drive)
- Check if motor phases are connected to the drive
- Check if motor phases are not interrupted by measuring its phase-to-phase resistance (use an ohmmeter; disconnect the motor from the Technosoft drive before performing this measurement)

The test will be validated through visual inspection of the graphical test results. If the controlled current reaches the reference current with acceptable performances (response time, overshoot, final error), you can validate the controller coefficients. Otherwise, change their parameters and execute the test until the results are satisfactory.

Pressing the OK button will save the actual values of controller parameters and return into the Drive dialog. Pressing Cancel button will leave controller parameters unchanged.

Note. You can save the results of a test, using the “Save Plots” button. You can also re-load results of previously saved tests, using the “Load Plots” button.

Step 5. In the “Speed Controller” group-box set the speed controller parameters **Kp** (proportional), **Ki** (integral) and **Integral limit** (saturation limit for the integral term of the controller).

Use the “Tune” button to compute these parameters based on the imposed dynamical performances of the closed loop, and on the system parameters. The “Speed Controller - Tuning” dialog will open in this case. If you set the **damp factor** and the **passband** of the closed control loop, the program will automatically compute the controller coefficients, based also on motion system parameter values. Expected system response to a step reference input in the controller is graphically displayed, as well as the frequency characteristic of the closed loop structure. Once you exit this dialog by pressing the **OK** button, the newly computed controller parameters replace the previous values.

If you are not comfortable with the damp factor and passband parameters, you may cancel the Speed Controller – Tuning dialogue and type directly the **Kp**, **Ki** coefficient values in the Speed Controller group-box:

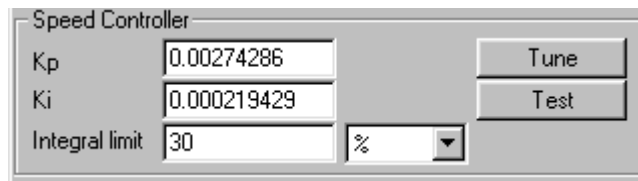

Figure 17. Speed Controller group-box

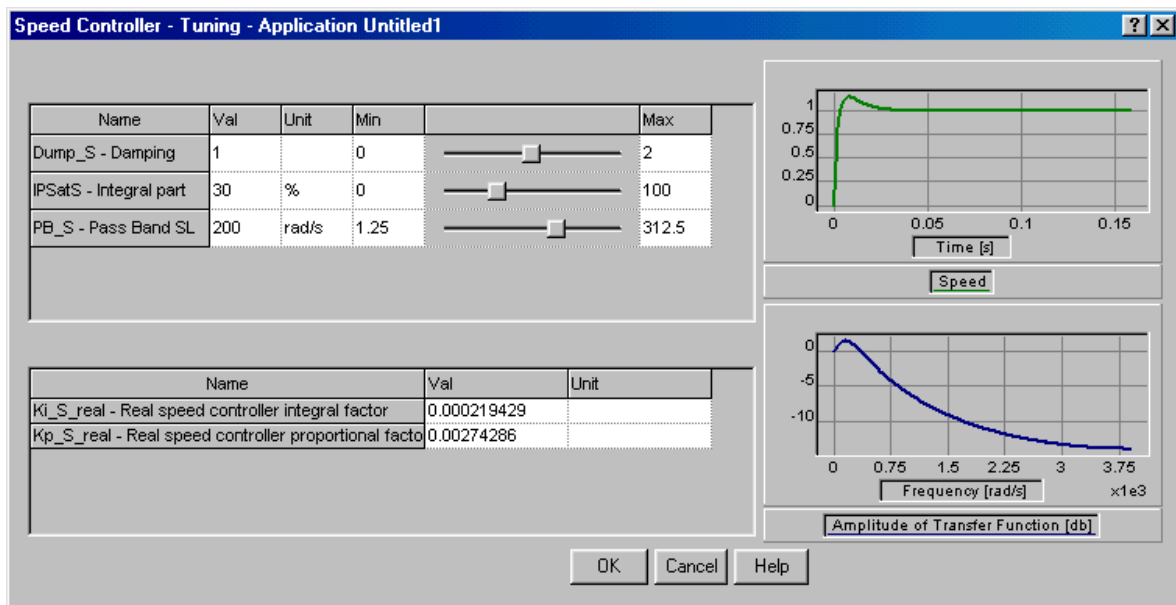

Figure 18. Speed Controller Tuning

Use the “**Test**” button in order to test a ramp response of the closed speed loop, for the actual values of the controller parameters. The “**Speed Controller Tuning Test**” dialog will open.

The test has two phases:

- Set-up test parameters (‘**Test parameters**’ tab)
- Run the test. (‘**Test**’ tab)

In the ‘**Test Parameters**’ tab you can define the test parameters: check the value of the speed reference to be used during the test, as well as the protection and limit current values.

The test applies power to the motor. It applies a speed profile (see graphical diagram), to the motor.

The “Ilimit” parameter is the value at which is limited the current value during the test, by the current controller. The “Iprotection” parameter is used to set the value of the current for which the over current protection will be activated during the test. If this value is attained during the test, the test execution is stopped. The “Istart” parameter is the value of the current used during the initial positioning of the motor (note that this parameter is needed only for a brushless motor, operating in the PMSM mode). See the time diagram included in the dialog in order to have a better understanding of the meaning of these parameters.

The test controls the speed applied to the motor as imposed by the user, as the speed profile from the “Test Parameters” group box. When entering the dialog, the program suggests a value for the Upper and Lower speed. You may change these values, in a specific range, limited by motor maximum accepted speed.

Trapezoidal or ramp profiles can also be generated, setting the acceleration and deceleration time intervals, tap and/or tan. Single or repetitive cycle movements can be selected using the Multiple Cycle Movement checkbox.

In order to perform the test, follow the “Test Procedure” indications.

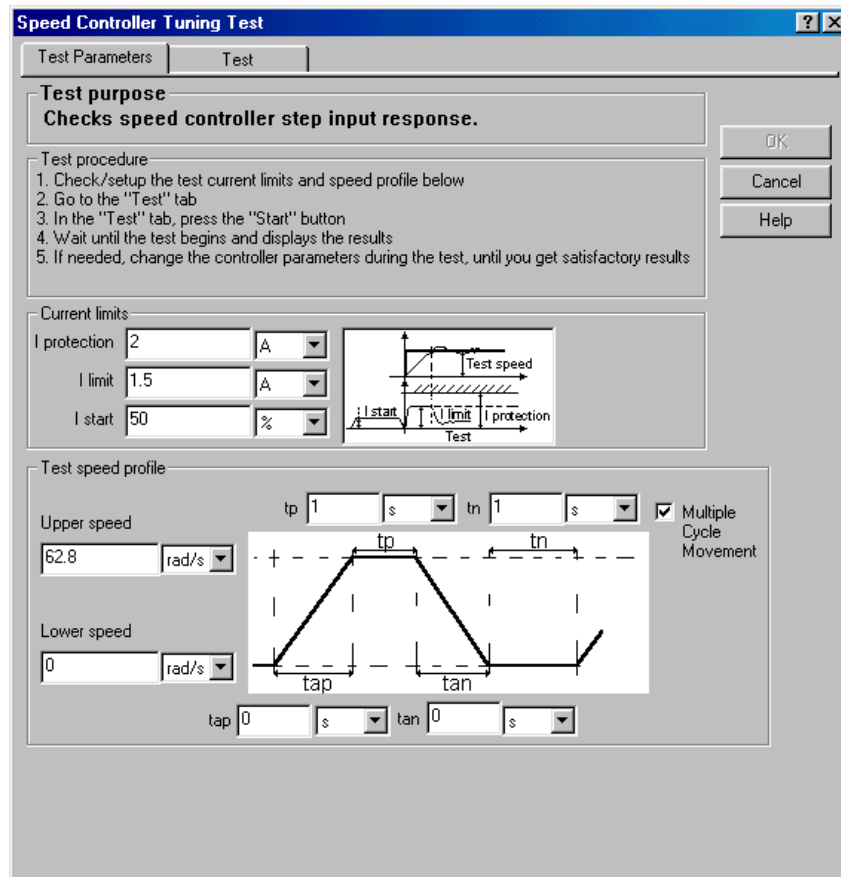

Figure 19.a. Speed Controller Tuning Test – 'Test Parameters' settings

The 'Test' tab is used to run the test. In this 'Test' tab press the Start button and wait until the test ends and displays the results. If needed, change controller until you get satisfactory results. If On-line plot option is selected, the reference (SPDREF) and measured (ASPD) speed values will be continuously displayed during the test (oscilloscope function). If Data logger option is selected, the reference (SPDREF) and measured (ASPD) speed values, (as well as the reference (IQREF) and measured (IQ) current values), are displayed at the end of the test.

You can change the controller parameters during test execution by modifying the value of the parameter in the corresponding edit box or by dragging the associated slider. To modify the range of values for the slider you can use the spin buttons (for minimum and for maximum limit values). Note that the current min/max range is a sub-range of the absolute range. The absolute limits are computed and depend on specific scaling factors and parameters of the system. Note that a sub-range of the maximum absolute range will allow fine adjustments of the parameters and eventually will reduce the risk of unstable control loop behavior at sudden changes of parameter value.

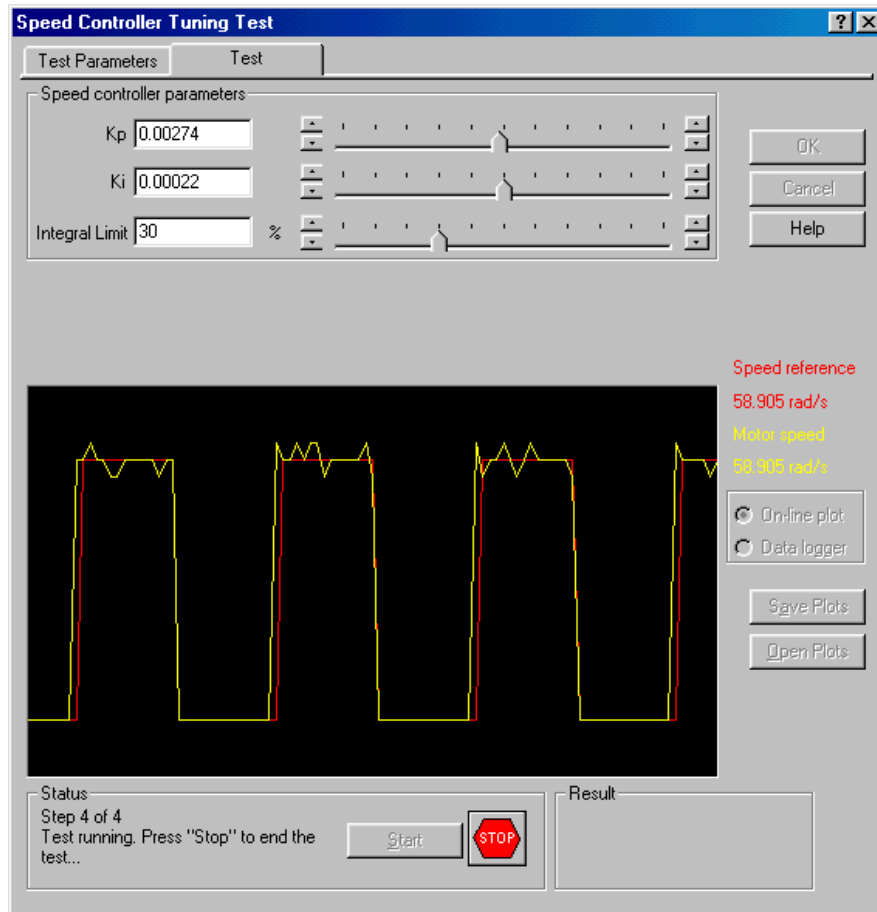

Figure 19.b. Speed Controller Tuning Test – ‘Test’ running

If the test fails, check the following:

- Check if the Technosoft drive is powered correctly (use for example, the “VDC Detection Test” from the Drive dialog, to measure the DC-link voltage applied to the power transistors of the Technosoft drive)

- Check motor phases connections (use for example, the “Test Phases Connections” from the Motor dialog)
- Check if the position sensor operates properly (use the tests associated to the position sensors from, the Motor dialog)
- Check motor parameters (eventually using the motor parameters identification tests from the Motor dialog)
- Check current controller parameters (use the “Current Controller Tuning Test”)

Test validation. The test will be validated through visual inspection of the graphical test results. If the controlled speed reaches the reference speed with acceptable performances (response time, overshoot, final error), you can validate the controller coefficients. Otherwise, change their parameters and execute the test until the results are satisfactory.

Pressing the OK button will save the actual values of controller parameters and return into the Drive dialogue. Pressing Cancel button will leave controller parameters unchanged.

Note. You can save the results of a test, using the “Save Plots” button. You can also re-load results of previously saved tests, using the “Load Plots” button.

Step 6. In the “**Position Controller**” group-box set the position controller parameters **Kp** (proportional), **Ki** (integral), **Kd** (derivative), **Kd filter** (filtering coefficient for the derivative term). Set also the **Integral limit** (saturation limit for the integral term of the controller) and **Speed limit** (saturation limit for the position controller output, seen as a speed reference value).

Use the “**Tune**” button to compute these parameters based on the imposed dynamical performances of the closed loop, and on the system parameters. The “**Position Controller - Tuning**” dialog will open in this case. If you set the **damp factor** and the **passband** of the closed control loop, the program will automatically compute the controller coefficients, based also on motion system parameter values. Expected system response to a step reference input in the controller is graphically displayed, as well as the frequency characteristic of the closed

loop structure. Once you exit this dialog by pressing the **OK** button, the newly computed controller parameters replace the previous values.

If you are not comfortable with the damp factor and passband parameters, you may cancel the Position Controller – Tuning dialogue and type directly the **Kp**, **Ki**, **Kd**, **Kd filter** coefficient values in the Position Controller group-box:

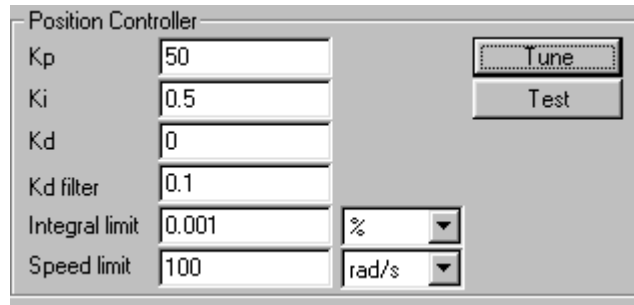

Figure 20. Position Controller group-box

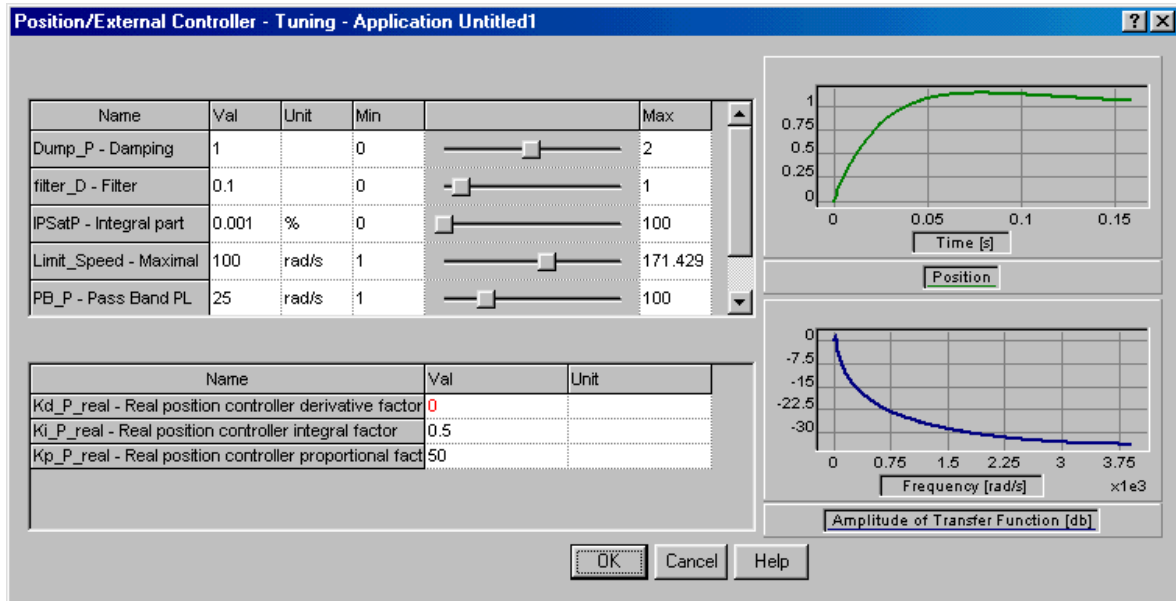

Figure 21. Position Controller Tuning

Use the **“Test”** button in order to test the step response of the closed position loop, for the actual values of the controller parameters. The **“Position Controller Tuning Test”** dialog will open.

The test has two phases:

- Set-up test parameters (**‘Test parameters’** tab)
- Run the test. (**‘Test’** tab)

In the **‘Test Parameters’** tab you can define the test parameters: check the value of the position reference to be used during the test, as well as the protection and limit current values.

The test applies power to the motor. It applies a position profile to the motor.

The "Ilimit" parameter is the value at which is limited the current value during the test, by the current controller. The "Iprotection" parameter is used to set the value of the current for which the over current protection will be activated during the test. If this value is attained during the test, the test execution is stopped. The "Istart" parameter is the value of the current used during the initial positioning of the motor (note that this parameter is needed only for a brushless motor, operating in the PMSM mode). See the time diagram included in the dialog in order to have a better understanding of the meaning of these parameters.

The test controls the position applied to the motor as imposed by the user, as the position profile from the "Test Parameters" group box. When entering the dialog, the program suggests a value for Upper and Lower position. You may change these values.

Trapezoidal or ramp profiles can also be generated, setting the acceleration and deceleration time intervals, tap and/or tan. Single or repetitive cycle movements can be selected using the Multiple Cycle Movement checkbox.

In order to perform the test, follow the "Test Procedure" indications.

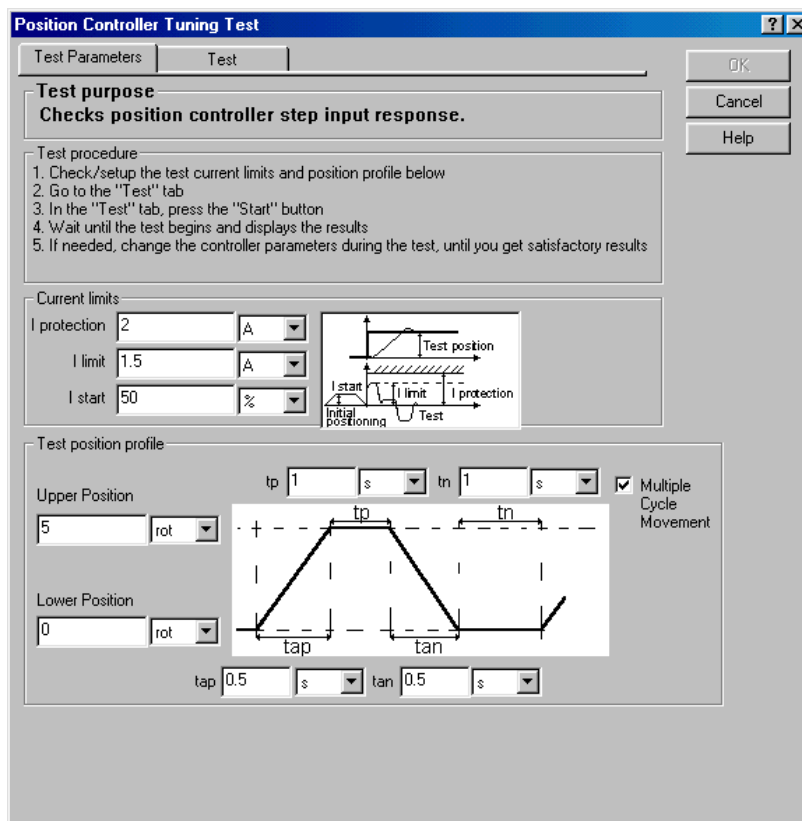

Figure 22.a. Position Controller Tuning Test – 'Test Parameters' settings

The 'Test' tab is used to run the test. In this 'Test' tab press the Start button and wait until the test ends and displays the results. If needed, change controller parameters and repeat the procedure (press the Start button etc.) until you get satisfactory results.

If On-line plot option is selected, the reference (TPOS) and measured (APOS) position values will be continuously displayed during the test (oscilloscope function). If Data logger option is selected, the reference (TPOS) and measured (APOS) position values, (as well as the reference (SPDREF) and measured (ASPD) speed values), are then displayed at the end of the test.

You can change the controller parameters during test execution by modifying the value of the parameter in the corresponding edit box or by dragging the associated slider. To modify the range of values for the slider you can use the spin buttons (for minimum and for maximum limit values).

Note that the current min/max range is a sub-range of the absolute range. The absolute limits are computed and depend on specific scaling factors and parameters of the system. Note that a sub-range of the maximum absolute range will allow fine adjustments of the parameters and eventually will reduce the risk of unstable control loop behavior at sudden changes of parameter value.

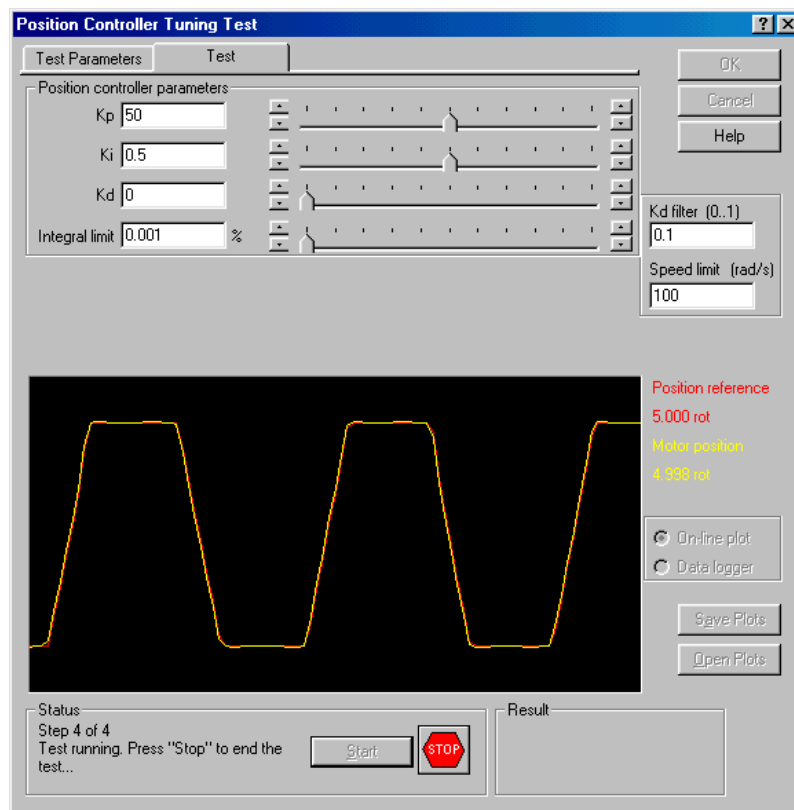

Figure 22.b. Position Controller Tuning Test – 'Test' running

If the test fails, check the following:

- Check if the Technosoft drive is powered correctly (use for example, the “VDC Detection Test” from the Drive dialog, to measure the DC-link voltage applied to the power transistors of the Technosoft drive)
- Check motor phases connections (use for example, the “Test Phases Connections” from the Motor dialog)
- Check if the position sensor operates properly (use the tests associated to the position sensors from, the Motor dialog)
- Check motor parameters (eventually using the motor parameters identification tests from the Motor dialog)
- Check current controller parameters (use the “Current Controller Tuning Test”)

Test validation. The test will be validated through visual inspection of the graphical test results. If the controlled position reaches the reference position with acceptable performances (response time, overshoot, final error), you can validate the controller coefficients. Otherwise, change their parameters and execute the test until the results are satisfactory.

Pressing the OK button will save the actual values of controller parameters and return into the Drive dialogue. Pressing Cancel button will leave controller parameters unchanged.

Note. You can save the results of a test, using the “Save Plots” button. You can also re-load results of previously saved tests, using the “Load Plots” button.

Step 7. In the “**Protections Controller**” group-box, select and parameterize those protections that you want to be activated during the motion. For a first evaluation, use the default settings and selections.

Step 8. For the “**Start mode**” group-box set up de corresponding parameters.

Step 9. Set the **Transition speed level** for **Transition speed from step-less to full step**.

Step 10. Press the **OK** button of the **Drive** dialog, in order to validate the defined control structure and its associated parameters.

6. Define and test the motion

Click on the **Motion** icon. The motion wizard dialog will be opened, as in Figure 23.

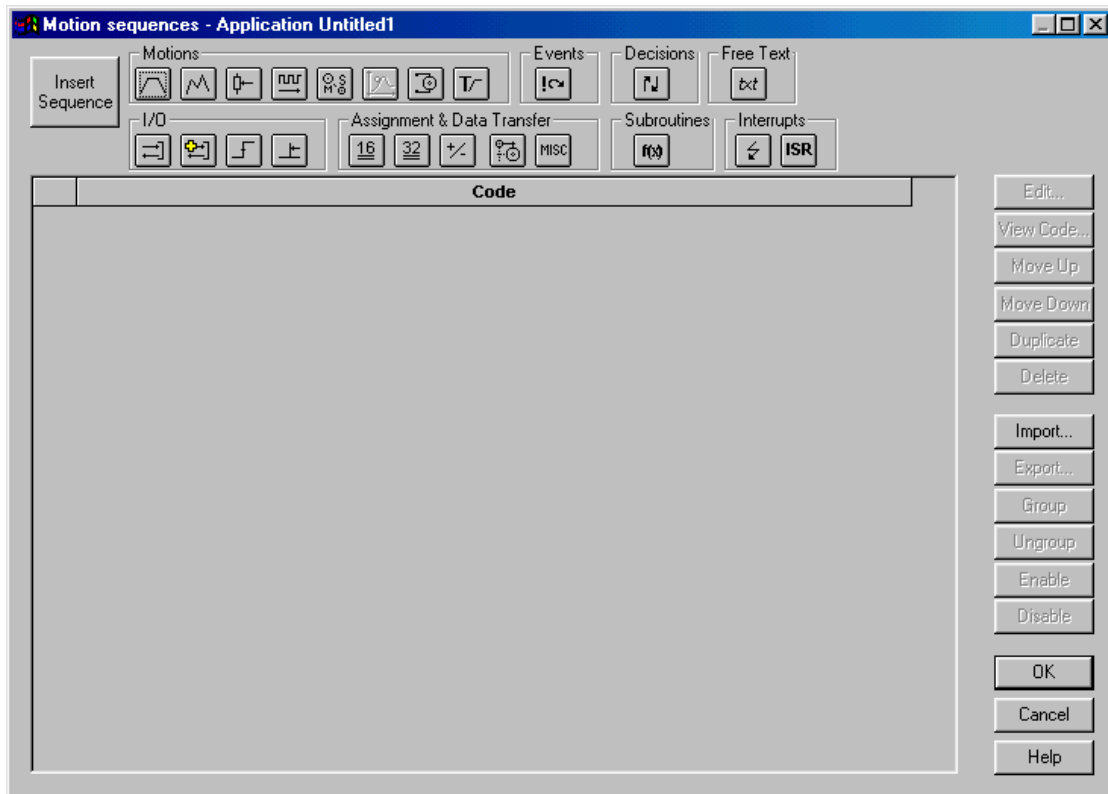

Figure 23. The Motion Wizard dialog

The dialog allows you to insert specific motion sequences and other TML commands, as arithmetic, I/O operations, events, etc. Details about the functionality and features of the Motion Wizard are given in Chapter 5 of "IPM Motion Studio User Manual".

In order to perform a simple motion, only to validate the complete overview of this paragraph, use the predefined motion sequence already defined in the motion profile by clicking the button



In the associated Motion Profiles dialog window you can define a position profile as you can see in the figure below:

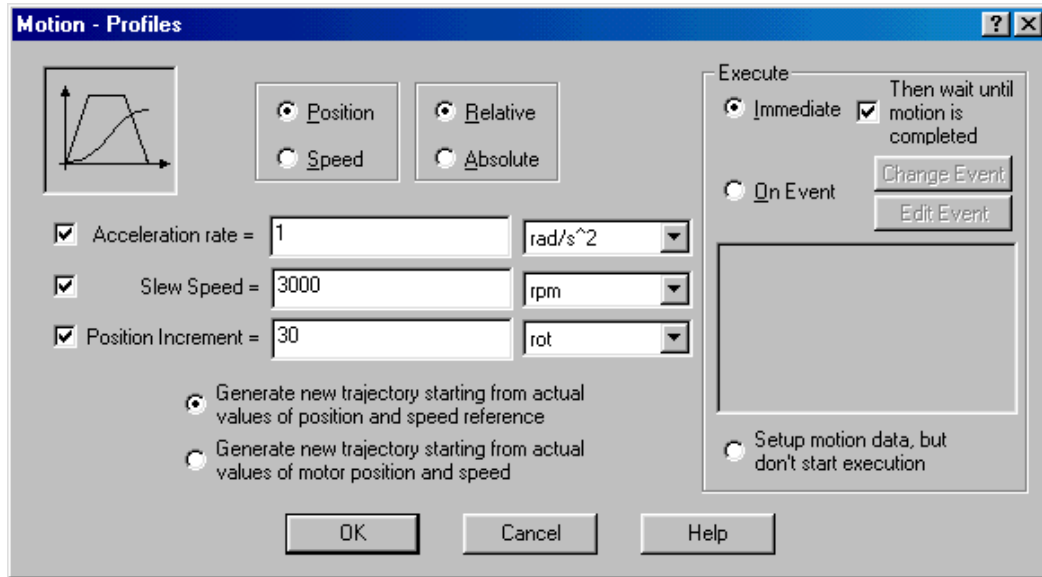

Figure 24. The Motion Profiles dialog

You can define the profile parameters, i.e. the acceleration/deceleration, the slew speed, and the reference position value.

Once the motion is defined, exit the Motion Wizard by pressing the **OK** button.



You can now generate the complete TML code associated to the chosen configuration, download it to the IPM drive, and execute it. You simply press the **Run** button, and all the operations associated to this command will be executed: reset the IPM, generate the TML code based on the configuration and imposed parameters, as well as on the motion, download the code to the IPM, and start its execution. The motor should execute the imposed motion.



You can upload the data logged during the motion by selecting the data logger window, click the right button of the mouse, and activate the **Upload Data** menu command. The variables stored during the execution of the motion will be displayed on the screen.



You can Stop the motor by disabling the PWM outputs (Stop the motion by Axisoff)



Reset the drive

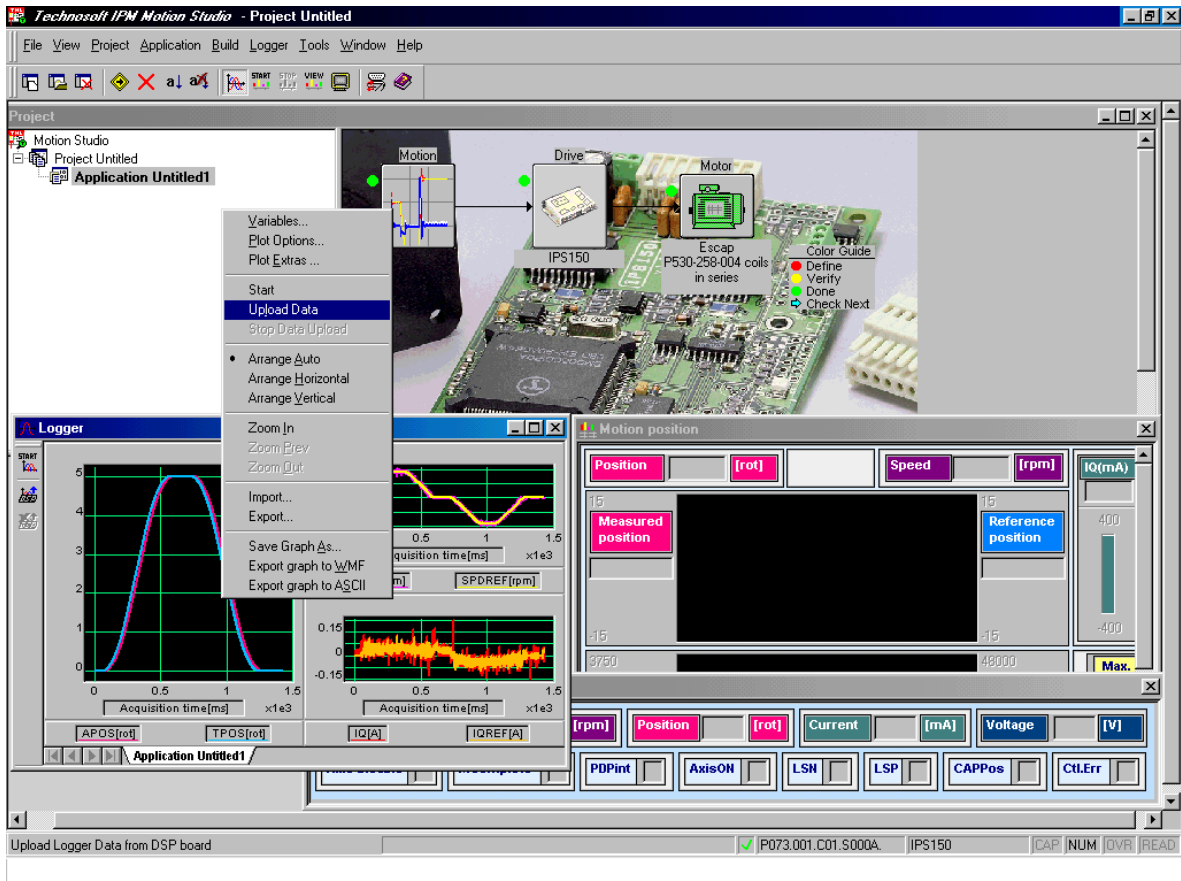

Figure 25. The Data Logger dialog

More details about the data analysis tools (Logger and Control Panel) are presented in the IPM Motion Studio User Manual.

7. Save and close the project

The precedent paragraphs guided you through the process of starting a motion project, configuring and parameterizing it, defining the motion and finally executing it on the IPS drive. As one can see from the described procedure, the steps to follow are straightforward, and allow you to validate the operation of your complete drive configuration.

When arrived at this point, you can start and really go into details related to all the features of the program, mainly focusing on the motion description and implementation.

The just defined project, completed with the correct structure definition and parameters of the elements (motor, sensors, controllers, etc.), can be saved for further use. Select the **"Project | Close"** menu command. You'll be asked to give a name for the project and the application to be saved. Latter on, you'll be able to open the project, in the same status as when saved the last time.

Drive layout:

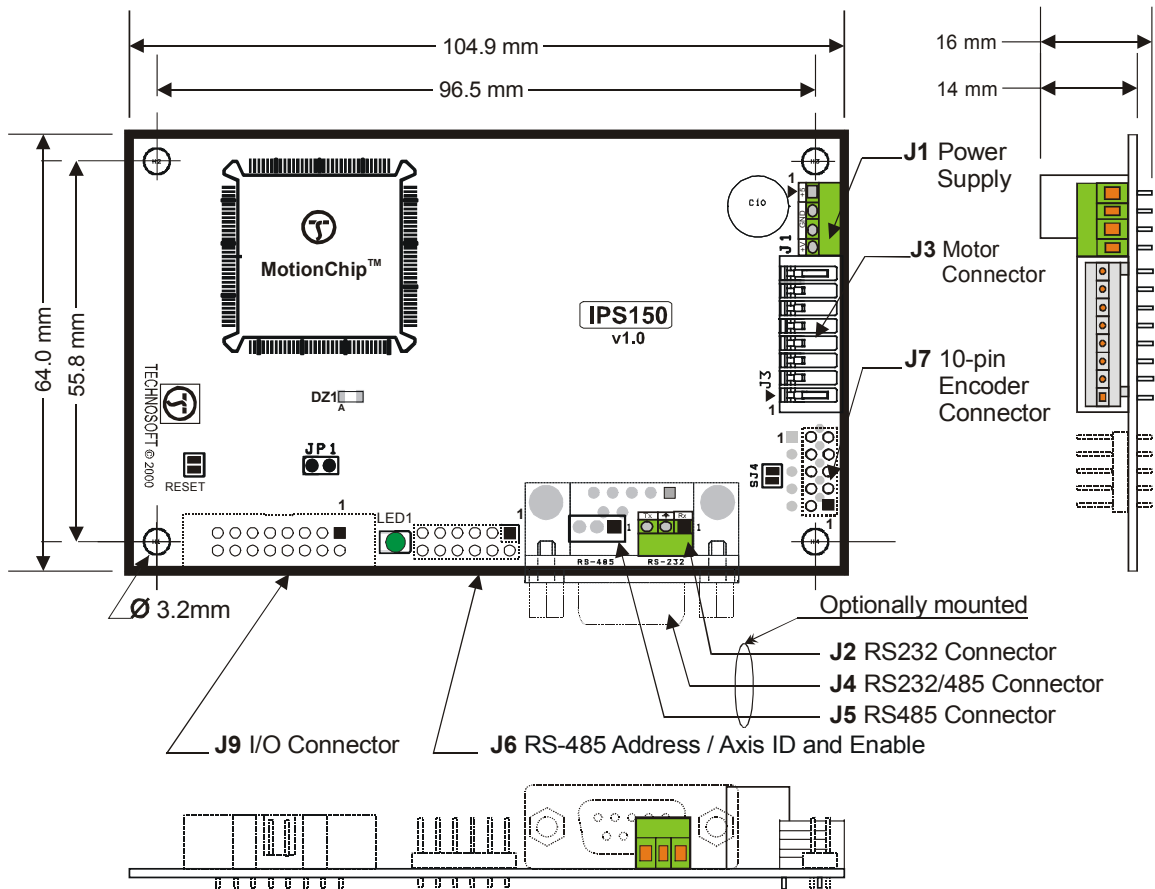

Figure 26. IPS150v1.0 drive layout

This page is empty