

PLC Applications Made Easy with Technosoft Motion Control Libraries

The new [TML_LIB_X20](#) Motion Control Library embeds the Technosoft drives intelligence in a B&R PLC environment. The library is a collection of high-level functions and blocks allowing the control of the Technosoft intelligent drives from a B&R PLC. It works with the B&R Automation Studio v3.0 SP3.

With TML_LIB functions, you can control Technosoft drives individually or grouped, by sending commands for simple (TS_MoveAbsolute), complex (TS_SetPVT, TS_PVTPoint, etc) or synchronized (TS_GearIn) motions. The library is completed by several non-motion driving functions and blocks necessary for drives management (TS_Power or TS_ReadStatus). All libraries' functions have been designed using the guidelines described in the PLC standards for motion control, so they can be integrated on any development platform that is IEC-61131-3 compliant.

Using TML_LIB directly from the PLC, you will be able: to communicate with the drive via CAN-bus; to send motion commands; to get information automatically or on request about drive status and to check or modify the drive parameters. In this way, TML_LIB_X20 allows you to focus on the main aspects related to your specific application, and to easily use the drive and execute motion commands, by calling the appropriate functions from the library.

Beside the functions presented in the PLC standards, the library also contains functions which implement specific features found only on the Technosoft drives (TS_MovePVT). The powerful motion control features of our intelligent drives are based on their high-level programmability in Technosoft Motion Language, a common programming platform for all these drives. Thus, TML_LIB_X20 offers you access to TML functionality, without the need to use any TML commands.

Therefore, TML_LIB_X20 represents the perfect tool for a quick implementation, on a B&R PLC, of motion control applications with Technosoft products.

Details can be found on:

http://www.technosoftmotion.com/products/OEM_PROD_TML_LIB_S7.htm

[TECHNOSOFT](#) is a leading motion control technology company specialized in the development, design and manufacture of motion control products and custom motion systems. We offer a complete line of OEM intelligent drive solutions which embed motion control, drive and PLC functionalities in a single compact unit. Based on [MotionChip™](#) DSP technology, they cover all type of brushless, DC, linear or step motor applications from 25 W up to 3 kW. All products are fully programmable using the built-in motion controller and the [EasyMotion Studio](#) software. Motion modes as contouring, profiling, gearing, electronic camming, PVT are easily executed in stand-alone or multi-axis configurations.

TECHNOSOFT
Buchaux 38
CH-2022 BEVAIX
Switzerland

Phone: +41 32 732 55 00
Fax: +41 32 732 55 04
sales@technosoftmotion.com
www.technosoftmotion.com

P091.PR.P040.TML_LIB_X20_0609_EN

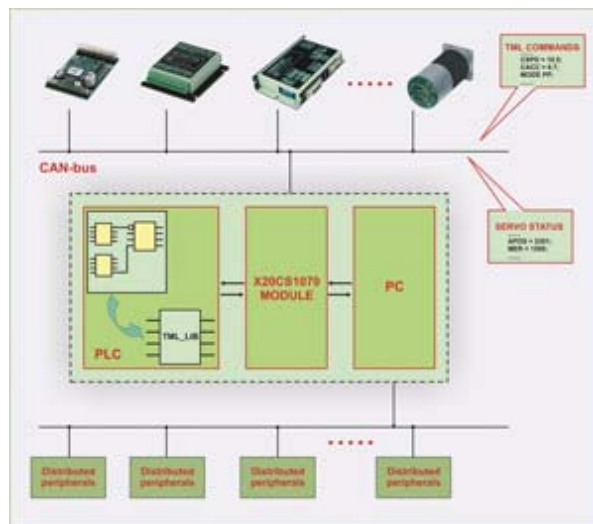

Your
Next
Intelligent
Move



TECHNOSOFT
MOTION TECHNOLOGY